

# **UNIVERSIDAD NACIONAL DE INGENIERÍA**

## **FACULTAD DE INGENIERÍA MECÁNICA**



### **Implementación de Mejoras en el Sistema de Medición de Gas en la línea de 2000 SCFD proveniente de los Pozos Gasíferos en el Distrito de los Órganos – Piura**

**INFORME DE SUFICIENCIA  
PARA OPTAR EL TÍTULO PROFESIONAL DE INGENIERO  
MECATRÓNICO**

**JUAN ANTONIO ARIAS SUAREZ**

**PROMOCIÓN 2009-II**

**LIMA - PERÚ**

**2013**

*Dedicado a mi familia, por el apoyo incondicional brindado a lo largo de toda mi vida y los siempre valiosos consejos que me han ayudado a convertirme en el profesional y persona que soy el día de hoy.*

*Agradezco todo el apoyo brindado por parte de la empresa Petrobras Energía del Perú S.A. para el desarrollo y publicación del presente proyecto, además también por haber permitido mi desarrollo profesional en el campo de Instrumentación y Control de Procesos.*

# ÍNDICE

PRÓLOGO.....	1
--------------	---

## **CAPÍTULO I:**

<b><u>INTRODUCCIÓN</u></b> .....	3
----------------------------------	---

1.1 Antecedentes.....	4
-----------------------	---

1.2 Objetivos.....	5
--------------------	---

1.2.1 Objetivo principal.....	5
-------------------------------	---

1.2.2 Objetivos específicos.....	5
----------------------------------	---

1.3 Alcance.....	5
------------------	---

1.4 Justificación.....	6
------------------------	---

1.5 Recursos empleados.....	6
-----------------------------	---

## **CAPÍTULO II:**

<b><u>MEDICIÓN DE GAS NATURAL</u></b> .....	8
---	---

2.1 Dispositivos de medición de gas natural.....	8
--	---

2.1.1 Definiciones.....	8
-------------------------	---

2.1.2 Principios de medición.....	12
-----------------------------------	----

2.1.3 Análisis metrológico de dispositivos de medición.....	15
---	----

## **CAPÍTULO III:**

<b><u>SELECCIÓN DE DISPOSITIVO DE MEDICIÓN DE CAUDAL</u></b> .....	19
--	----

3.1 Forma de medición encontrada basada en el método de la placa orificio.....	19
--	----

3.1.1 Condiciones operativas.....	19
3.1.2 Condiciones de la instalación del puente.....	20
3.1.3 Estado y condición encontrada del dispositivo de medición de Caudal.....	23
3.1.4 Análisis de las fuentes del error encontrado en la medición del caudal de gas.....	25
3.2 Selección de tecnología a utilizar.....	27
3.2.1 Características requeridas para dispositivo de medición.....	27
3.2.2 Selección de tecnología de medición.....	29
3.3 Especificación del dispositivo a utilizar.....	31

#### **CAPÍTULO IV:**

<b><u>INSTALACIÓN COMPONENTES PUENTE DE MEDICIÓN.....</u></b>	<b>34</b>
4.1 Instalación mecánica del dispositivo.....	34
4.1.1 Características mecánicas.....	34
4.1.2 Plano de montaje.....	35
4.2 Instalación eléctrica del dispositivo.....	35
4.2.1 Características eléctricas.....	35
4.2.2 Diagrama unifilar.....	35
4.3 Parametrado del dispositivo.....	36
4.3.1 Parámetros de medición.....	36

**CAPÍTULO V:****PUESTA A PUNTO DE LÍNEA DE MEDICIÓN DE GAS.....40**

5.1 Requisitos para pruebas con línea de medición.....	40
5.1.1 Normatividad.....	40
5.1.1 Datos requeridos para prueba.....	41
5.1.2 Formato de pruebas.....	42
5.2 Pruebas operacionales con dispositivo de medición.....	43
5.2.1 Resultados obtenidos.....	43
5.2.2 Análisis metrológico de resultados.....	47

**CAPÍTULO VI****EVALUACIÓN ECONÓMICA.....51**

6.1 Costos de nueva línea de medición.....	51
6.1.1 Costo de ingeniería.....	51
6.1.2 Costo de equipo.....	52
6.1.3 Costo de montaje.....	52
6.2 Beneficios de nuevo sistema.....	54
6.2.1 Beneficios por la mejora en la medida.....	54
6.2.2 Beneficio por la demanda de mantenimiento.....	55
6.3 Estimación de tiempo de recuperación de la inversión.....	55
6.3.1 Gráfico de Punto de Equilibrio.....	55

<b>CONCLUSIONES.....</b>	<b>64</b>
<b>BIBLIOGRAFÍA.....</b>	<b>65</b>
<b>ANEXOS.....</b>	<b>66</b>

## PRÓLOGO

El uso del gas natural en el Perú se ha incrementado en la última década, lo cual hace que las empresas extractoras de gas tengan una mayor demanda del recurso. Principalmente, el gas natural se utiliza para la generación de electricidad en regiones donde no se tiene cubierta la demanda con centrales hidroeléctricas. En consecuencia, se requiere estimar la cantidad de gas existente en los pozos con una muy buena precisión para garantizar la oferta.

En el distrito de Los Órganos, provincia de Talara, departamento de Piura la empresa Petrobras Energía del Perú tiene la concesión del Lote X. En el área se tienen pozos gasíferos cuya explotación requiere tomar mediciones de caudal lo cual no es factible realizar con los instrumentos disponibles en el mercado.

En el caso de la zona de Órganos, se tiene la estación de medición y almacenamiento de Crudo y Gas (Batería) OR-11, en la cual se realizó el Proyecto Piloto de Medición de Gas, materia del presente informe, con una tecnología



diferente a la de placa orificio, utilizada actualmente. En este trabajo, se presenta la manera en la que se ha desarrollado el proyecto piloto. Se presentan seis capítulos, cuyos contenidos son los siguientes:

En el Capítulo I se precisa los antecedentes, objetivos, alcance, justificación y los recursos empleados en la implementación del sistema de medición.

En el Capítulo II se presenta el marco teórico de las diferentes tecnologías de medición de gas, así como las definiciones relacionadas a la metrología a tener en cuenta.

En el Capítulo III se detalla la manera cómo opera la planta y los rangos de presión, temperatura y caudal encontrados. Además se realiza la selección de la tecnología de medición para mejorar la performance del equipo.

En el Capítulo IV se presenta la manera en que se desarrolló el montaje mecánico, eléctrico y la parametrización del caudalímetro seleccionado en el capítulo anterior.

En el Capítulo V se muestran los protocolos de pruebas y los resultados de la medición con el nuevo caudalímetro que fue instalado.

En el Capítulo VI se presenta el análisis económico del proyecto para proyectar su utilización en las 29 plantas restantes del Lote X.

Finalmente, se presentan las conclusiones y los anexos correspondientes a cada tema.

# **CAPÍTULO I**

## **INTRODUCCIÓN**

En la actualidad, el crecimiento económico del Perú requiere cada día una mayor oferta de energía proveniente de fuentes alternativas como el gas natural. Debido a ello la empresa privada requiere una mayor inversión para poder optimizar el proceso de extracción y medición del gas para poder comerciar el mismo en contratos de compra – venta en forma precisa. En consecuencia, se debe conocer con la mayor exactitud posible el volumen disponible de Gas Natural.

La medición de volumen de Gas Natural es normalmente realizada con un sistema cuyo funcionamiento se basa en el principio de Bernoulli y que tiene como componente principal la placa orificio. Sin embargo, este sistema presenta problemas debido a que su empleo está restringido a rangos de caudal y presión pequeños. Por lo tanto se requiere un caudalímetro que pueda manejar altas variaciones de caudal y presión al realizar las medidas sin variar significativamente su exactitud.

Para el desarrollo del presente Informe se utilizará el Sistema Métrico Inglés, debido a que su uso es muy difundido en el rubro de la explotación del gas.

## **1.1 Antecedentes**

La extracción de Crudo y Gas en el norte del país se inició en la década de 1880, actualmente está dividido en Lotes de extracción. Uno de estos lotes es el Lote X que desde el año 1997 está concesionado a la empresa Petrobras Energía Perú S.A. hasta el año 2024.

Desde los inicios de extracción de gas, el volumen se ha medido con la tecnología de medición de Placas Orificio habiéndose estandarizado esta forma de medir en todas las instalaciones del Lote X (incluyendo el Punto de Venta)

Los caudales de medición de gas en el Lote X son altamente variables y con ello la placa orificio tiene una baja performance. Por ello en el año 2010 la Gerencia de Servicios Técnicos en conjunto con la Gerencia de Operaciones del Lote X inician un proyecto de medición de gas con una tecnología diferente a las placas orificio. De lo anterior el problema queda identificado con la siguiente pregunta:

¿Es factible implementar un sistema de medición de gas natural mejorado en los Separadores de Prueba del Lote X?

La hipótesis del trabajo fue que sí es posible realizar dicha implementación.

## **1.2 Objetivos**

### **1.2.1 Objetivo General**

Estudiar la factibilidad de implementar un Sistema de Medición de Gas Natural mejorado en los Separadores de Prueba del Lote X.

### **1.2.2 Objetivos Específicos**

Los objetivos específicos que sirvieron de soporte para lograr el objetivo principal fueron los siguientes:

- a) Seleccionar un dispositivo de medición de caudal basado en el principio de dispersión térmica
- b) Instalar el nuevo puente de medición para una correcta performance del dispositivo de dispersión térmica.
- c) Analizar la precisión del dispositivo y verificar que se encuentre dentro del límite permisible (1% del Span o rango máximo)

## **1.3 Alcance**

El presente informe desarrolla la selección, implementación y análisis de la precisión de un caudalímetro para la medición de gas los separadores de prueba del Lote X. En estos separadores de prueba se manejan caudales altamente variables debido a que se utiliza para la medición de gas de diferentes pozos cada 2 días, es

decir un día un pozo puede producir una cantidad  $x$ , pero el pozo siguiente puede producir  $5x$  o  $10x$ .

El alcance del presente proyecto está delimitado por la implementación de un sistema de medición de gas natural basado en el principio de dispersión térmica hecha en el Separador de Prueba 5 de la Batería OR-11, el cual es probado con un patrón basado en la tecnología de placa orificio. Luego se realiza el análisis de la implementación del sistema en todos los separadores de prueba del Lote X.

Queda fuera del alcance del presente informe la integración de la lectura de caudal en el PLC local de la batería, así como la visualización en el Sistema SCADA.

#### **1.4 Justificación**

El presente proyecto se justifica porque es la respuesta técnica ante un requerimiento de la alta dirección de la empresa Petrobras, cuya realización evidenció por el aporte tecnológico consistente en el caudalímetro de dispersión térmica con su respectivo puente de medición que funciona con un alto índice de precisión.

#### **1.5 Recursos Empleados**

Para realizar el proyecto se emplearon los siguientes recursos:

- 1.- Tecnologías de Medición: Placa Orificio, Dispersión Térmica
- 2.- Personal de las empresas: Petrobras Energía del Perú S.A. (Gerencia de Operaciones, Gerencia de Servicios Técnicos), Proyectos y Controles S.A.

(suministro de nuevo caudalímetro, parametrización y pruebas), FELECIN (montaje mecánico, eléctrico y pruebas de caudalímetro)

3.- Principales máquinas y herramientas: Retroescavadora, Tablero de Paso, Cables de Instrumentación, Tubería PVC, Caudalímetro, Bridas clase 150.

4.- Normativa: AGA (American Gas Association) 8, ISO 5167.

# **CAPÍTULO II**

## **MEDICION DE GAS NATURAL**

### **2.1 Dispositivos de Medición de Gas Natural**

#### **2.1.1 Definiciones**

- **Exactitud**

Cualidad de un instrumento de medida por la que tiende a dar lecturas próximas al verdadero valor de la magnitud medida. En términos estadísticos, la exactitud está relacionada con el sesgo de una estimación, es decir cuanto menor es el sesgo se tendrá un valor más representativo de la variable medida.

También se puede considerar a la exactitud como la cercanía del valor experimental obtenido, con el valor exacto de dicha medida. El valor exacto de una magnitud física es un concepto utópico, ya que es imposible conocerlo sin incertidumbre alguna (*Fuente: Creús Solé. Antonio, Instrumentación Industrial. México: Alfaomega, 2011*)

- Precisión

Tolerancia de medida del instrumento para dar el mismo resultado en diferentes mediciones. En términos estadísticos, la precisión es la dispersión del conjunto de valores obtenidos de mediciones repetidas de una magnitud. *(Fuente: Creús Solé, Antonio, Instrumentación Industrial. México: Alfaomega, 2011)*

- Repetibilidad

Grado de concordancia en la medición de la señal de salida del Instrumento bajo las mismas condiciones de servicio, así como el sentido de variación a lo largo de todo el campo. *(Fuente: Creús Solé, Antonio, Instrumentación Industrial. México: Alfaomega, 2011)*

- Error

Diferencia algebraica entre el valor indicado por el instrumento y el valor considerado ideal. Normalmente este valor ideal viene indicado por un medidor patrón o también puede considerarse al instrumento con menor incertidumbre como referencia. *(Fuente: Creús Solé, Antonio, Instrumentación Industrial. México: Alfaomega, 2011)*

- Rango de Medición

Región o campo de valores entre los límites donde una cantidad es medida, expresada por los valores superior e inferior. *(Fuente: Creús Solé, Antonio, Instrumentación Industrial. México: Alfaomega, 2011)*



- Span

Diferencia entre el valor superior y valor inferior del rango de medición.

*(Fuente: Creús Solé, Antonio, Instrumentación Industrial. México: Alfaomega, 2011)*

- Rangeabilidad

Razón entre el valor máximo de medición del instrumento con respecto al valor mínimo donde se mantiene la exactitud indicada en la especificación técnica.

*(Fuente: Creús Solé, Antonio, Instrumentación Industrial. México: Alfaomega, 2011)*

- Pozo Petrolífero o petrolero

Perforación suelo diseñada con el objetivo de hallar y extraer fluido combustible, principalmente petróleo.

- Crudo

Petróleo extraído de manera natural o artificial de los pozos petroleros y enviado a través de la red de oleoductos hacia la refinería para su tratamiento.

- Gas Asociado

Mezcla de gases ligeros (principalmente Metano) presente en el pozo petrolero ya sea disuelto o asociado con el mismo.

- SCFD (Standard Cubic Feet per Day – Pie Cúbico Estándar por Día)

Caudal Volumétrico de Gas corregido a condiciones estándar de presión y temperatura. Existen diversas definiciones a nivel mundial de las condiciones estándar, sin embargo las que se utilizarán en el presente informe son las siguientes:

$$P_{standard} = 101,325 \text{ Pa} \qquad T_{standard} = 60^{\circ}\text{F} (15,556^{\circ}\text{C})$$

La fórmula de conversión entre el caudal volumétrico real y el SCF es la siguiente:

$$SCF = ACF \frac{P_{actual}}{P_{standard}} \frac{T_{standard}}{T_{actual}}$$

Donde:

ACF (Actual Cubic Foot): Caudal real medido en Pie Cúbico (por segundo, minuto u hora)

Recordar que  $1 \text{ ft}^3 = 0,028 \text{ m}^3$

$P_{actual}, T_{actual}$ : Presión y Temperatura medida en condiciones de operación en unidades absolutas (Presión: Pascales, Temperatura: Kelvin, Grados Rankine)

*(Fuente: Gallagher, James, Natural Gas Measurement Handbook Estados Unidos: Gulf Publishing Company, 2006)*

### 2.1.2 Principios de medición

- Presión Diferencial (Placa Orificio)

El principio de medición se basa en el Teorema de Bernoulli (Altura Cinética + Altura de Presión + Altura Potencial = cte.) La explicación del mismo aplicado en el caso de una Placa Orificio se aprecia en la figura 2.1

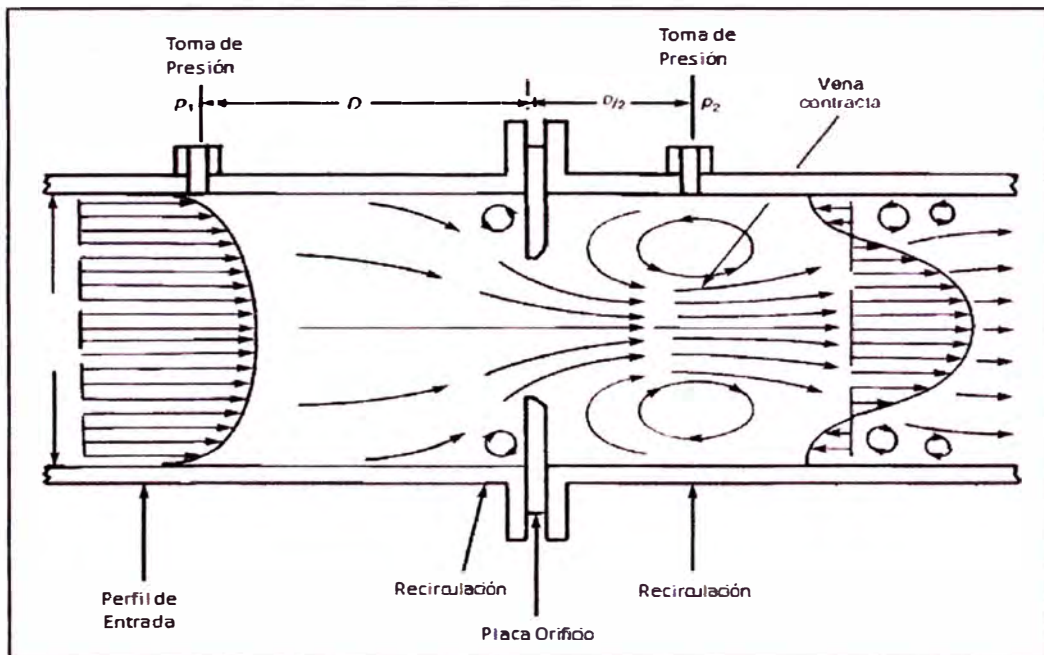

**Fig. 2.1** Diagrama de Variación de Presión en Placa Orificio

De acuerdo al Teorema de Bernoulli tenemos:

$$\frac{P_1}{\rho g} + \frac{V_1^2}{2g} + Z_1 = \frac{P_2}{\rho g} + \frac{V_2^2}{2g} + Z_2 \quad (1)$$

Debido a que las alturas tomadas para el análisis son iguales queda en la expresión 1:

$$\frac{P_1}{\rho} + \frac{V_1^2}{2} = \frac{P_2}{\rho} + \frac{V_2^2}{2} \quad (2)$$

Despejando la Velocidad en el punto 2 tenemos:

$$V_2 = \frac{\sqrt{\frac{2(P_1 - P_2)}{\rho}}}{1 - \frac{d^4}{D^4}} \quad (3)$$

Siendo:

d: Diámetro de orificio

D: Diámetro Interno de Tubería

Se introducen a continuación las siguientes variables:

$\beta = \frac{d}{D}$  Relación de Diámetros

$E = \frac{1}{1-\beta^4}$  Coeficiente de velocidad de acercamiento

Reemplazando en la expresión 3, obtenemos:

$$V_2 = E \sqrt{2 \frac{P_1 - P_2}{\rho}} \quad (4)$$

Expresando el resultado en Caudal, tenemos:

$$Q = S_2 * V_2 = E \frac{\pi d^2}{4} \sqrt{2 \frac{P_1 - P_2}{\rho}} \quad (5)$$

A la expresión 5 se le agrega un coeficiente experimental de expansión  $\varepsilon$  para tomar en cuenta los efectos de expansión ocurridos durante la aceleración del flujo en la placa orificio. Este coeficiente es función de la relación de presiones, relación de calores específicos para fluidos incompresibles y de la relación  $\beta$ , con ello obtenemos la expresión 6.

$$Q = S_2 * V_2 = E \varepsilon \frac{\pi d^2}{4} \sqrt{2 \frac{P_1 - P_2}{\rho}} \quad (6)$$

(Fuente: Creús Solé, Antonio, *Instrumentación Industrial. México: Alfaomega, 2011*)

- Dispersión Térmica

La ecuación básica que gobierna la relación entre la tasa de transferencia de calor y la velocidad del fluido de un cilindro insertado en el mismo, fue formulada por King (1914) de la siguiente forma:

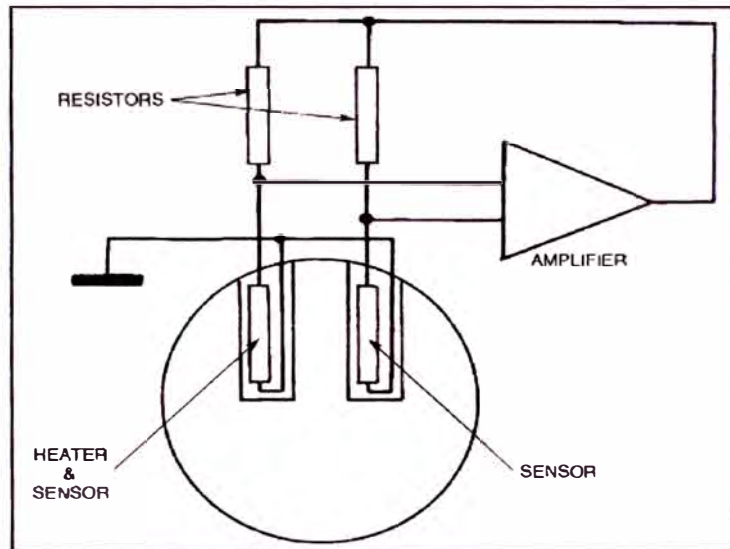

**Fig. 2.2** Dibujo Esquemático de un arreglo de Puente Wheatstone para un Caudalímetro de Dispersión Térmica

$$q_h = k\Delta T + (2\pi k c_p \rho d V)^{0.5} \Delta T \quad (7)$$

Donde:

$k$ : Conductividad Térmica del Fluido

$c_p$ : Calor Específico del Fluido a una Presión Constante

$\rho$ : Densidad

$V$ : Velocidad del Fluido (se asume que es perpendicular al cilindro)

$d$ : Diámetro del Cilindro

$q_h$ : Tasa de Transferencia de Calor

Se agrupan los términos de la siguiente manera:

$$C = k\Delta T$$

$$D = (2\pi k c_p \rho d)^{0.5} \Delta T$$

Considerando la Ley de Ohm y agrupando términos, obtenemos:

$$q_h = VI = I^2R = C + DV^{0.5} \quad (8)$$

Donde C y D son funciones de la temperatura para un determinado fluido. Si la resistencia del cilindro se mantiene constante, entonces la temperatura también será constante y en efecto C y D serán constantes del caudalímetro para un fluido en particular.

Como se aprecia en la ecuación 8, con sólo medir la tensión o corriente (Figura 2) en el Puente Wheatstone se puede obtener la velocidad para un fluido determinado.

*(Fuente: Baker, Roger, Flow Measurement Handbook. Estados Unidos: Cambridge University Press, 2005)*

### 2.1.3 Análisis Metrológico de dispositivos de medición

- Presión Diferencial

Se plantea nuevamente la ecuación 6:

$$Q = E\varepsilon \frac{\pi d^2}{4} \sqrt{\frac{P_1 - P_2}{\rho}}$$

Se ingresa nuevamente el valor de E para obtener la expresión desarrollada del Caudal en la Placa Orificio:

$$Q = \varepsilon \frac{\pi d^2}{4} \sqrt{\frac{P_1 - P_2}{\rho(1-\beta^4)}} \quad (8)$$

La expresión para la incertidumbre de acuerdo a la Teoría de Propagación de Errores es la siguiente:

$$\frac{\delta q_m}{q_m} = \left\{ \left( \frac{\delta C}{C} \right)^2 + \left( \frac{\delta \epsilon}{\epsilon} \right)^2 + \left( \frac{2\beta^4}{1-\beta^4} \right)^2 \left( \frac{\delta D}{D} \right)^2 + \left( \frac{2}{1-\beta^4} \right)^2 \left( \frac{\delta d}{d} \right)^2 + \frac{1}{4} \left( \frac{\delta \Delta p}{\Delta p} \right)^2 + \frac{1}{4} \left( \frac{\delta \rho_1}{\rho_1} \right)^2 \right\}^{1/2} \quad (9)$$

La estimación de las incertidumbres de cada variable se estima de acuerdo a las Normas ISO 5167 – Partes 1 y 2:

- ✓ Incertidumbre del Coeficiente de Descarga  $\left( \frac{\delta C}{C} \right)$

La incertidumbre relativa al Coeficiente de Descarga es igual

a:

(0,7 – β)	para 0,1 ≤ β < 0,2 ;
0,5%	para 0,2 ≤ β < 0,6 ;
(1,667β - 0,5)%	para 0,6 ≤ β ≤ 0,75

Para  $D < 71,12$  mm (2,8 pulgadas), se deberá agregar aritméticamente la siguiente incertidumbre al valor calculado anteriormente:

$$0,9 \quad 0,75 - \beta \quad 2,8 - \frac{D}{25,4} \quad \%$$

Si  $\beta \geq 0,5$  y  $Re_D < 10000$  se deberá agregar 0,5% al valor calculado anteriormente.

- ✓ Incertidumbre del Coeficiente de Expansión  $\left( \frac{\delta \epsilon}{\epsilon} \right)$

La incertidumbre asociada al Coeficiente de Expansión es la siguiente:

$$\frac{\delta \epsilon}{\epsilon} = 3,5 \frac{\Delta p}{kP_1}$$

dónde:

$$K = \frac{\sqrt{1 - \beta^4(1 - C^2)}}{C\beta^2} - 1 \quad ^2$$

- ✓ Incertidumbre de la Diferencia de Presión ( $\frac{\delta\Delta p}{p}$ )

Se tienen 2 expresiones aproximadas para la estimación de la incertidumbre:

$$\frac{\delta\Delta p}{p} = \frac{\sqrt{1 - \beta^4(1 - C^2)} - C\beta^2}{\sqrt{1 - \beta^4(1 - C^2)} + C\beta^2} \Delta p$$

$$\frac{\delta\Delta p}{p} = 1 - \beta^{1,9}$$

- ✓ Incertidumbre de los Diámetros de Tubería y Orificio ( $\frac{\delta D}{D}$  y  $\frac{\delta d}{d}$ )

En la ISO-5167 se especifica que se pueden tomar los siguientes valores máximos para estas incertidumbres:

$$\frac{\delta D}{D} = 0,4\%$$

$$\frac{\delta d}{d} = 0,1\%$$

Para el presente trabajo no se considerará la contribución de la incertidumbre debido a la densidad del fluido por su baja contribución a la incertidumbre general. Se realizó el cálculo de la misma y es apenas 0.00078% (Para mayor detalle ver Anexo 1 – Cálculo de Incertidumbre de la densidad)

La exactitud típica de la Placa Orificio es de 1 a 3% del Span con una rangeabilidad de 3 a 1 variable en el rango de medición. Fuera de este rango la incertidumbre del equipo puede llegar a valores muy altos



(10% a más mientras más alejado se encuentre la medición del rango permitido)

- **Dispersión Térmica**

En el caso de los caudalímetros con la tecnología de Dispersión Térmica se presenta una situación completamente diferente a la descrita anteriormente: la rangeabilidad del equipo es de por lo menos 50 a 1 con una incertidumbre del 2% del caudal leído dentro de la banda de 1 a 4% del Valor Máximo del Rango de Medición.

Debido a la tecnología presentada (Inserción con sondas) la caída de presión es muy baja (máximo 10 mbar) Además esta tecnología está diseñada para presiones altas (normalmente alrededor de 40 bar)

*(Fuente: Baker, Roger, Flow Measurement Handbook. Estados Unidos: Cambridge University Press, 2005)*

En el presente capítulo quedan explicados los conceptos básicos empleados y se observa que el principio de dispersión térmica ofrece una incertidumbre de medición más baja que la de la placa orificio.

# **CAPÍTULO III**

## **SELECCIÓN DE DISPOSITIVO DE MEDICIÓN DE CAUDAL**

### **3.1 Forma de Medición encontrada basada en el Método de la Placa Orificio**

#### **3.1.1 Condiciones Operativas**

Se tienen pozos de producción de crudo en la Batería OR-11, los cuales envían la producción a los Manifolds de Campo y luego llegan a los Separadores de Totales y de Prueba de la Batería OR-11. De la parte superior del Separador se obtiene el Gas Asociado por separación física mientras que de la parte inferior se obtiene la mezcla agua-crudo. Se presenta el diagrama del proceso de la batería de producción en la figura 3.1.

En el caso de la Batería OR-11 se tiene un tren de medición del separador de totales y seis de los separadores de pruebas. La implementación del prototipo fue realizada en el separador de pruebas 5.

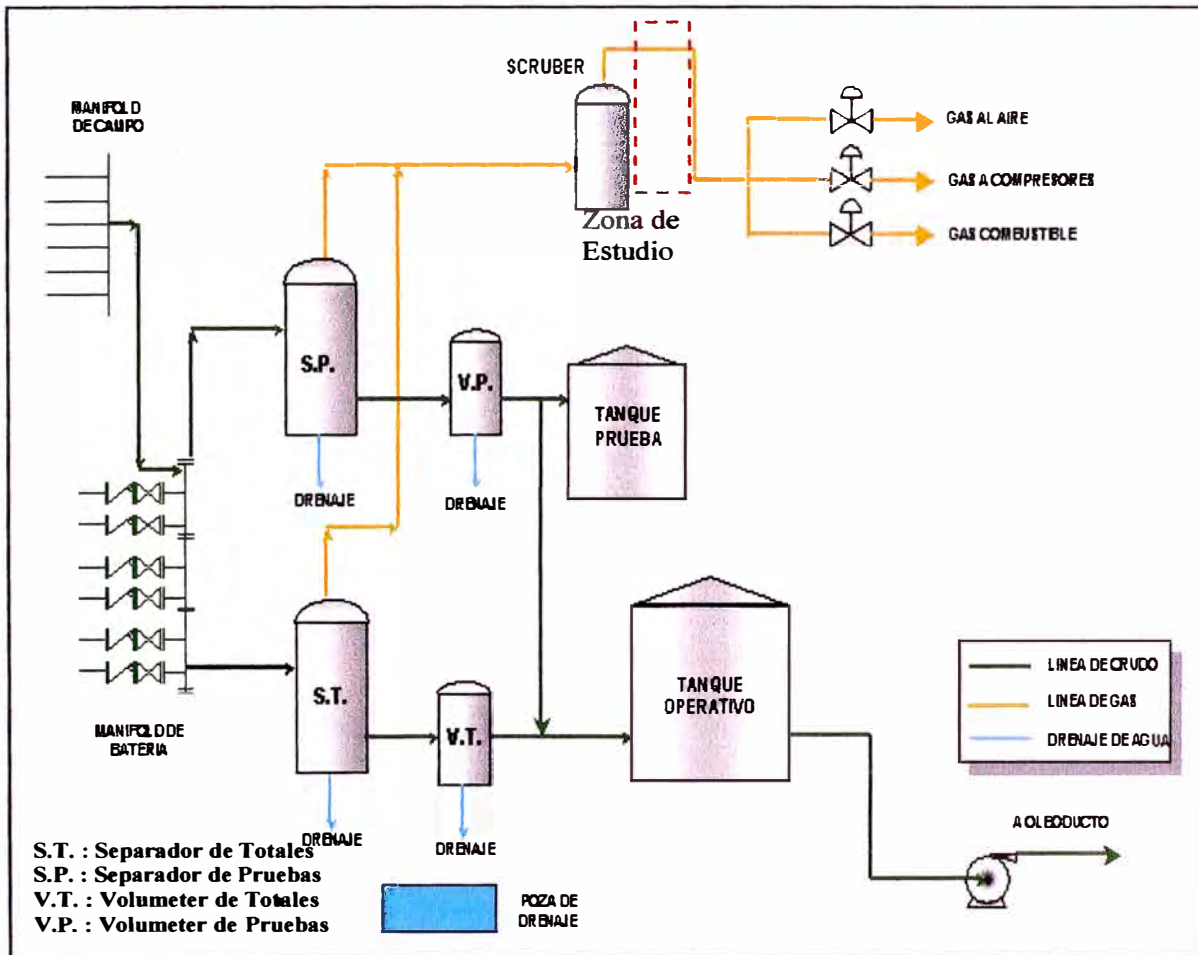
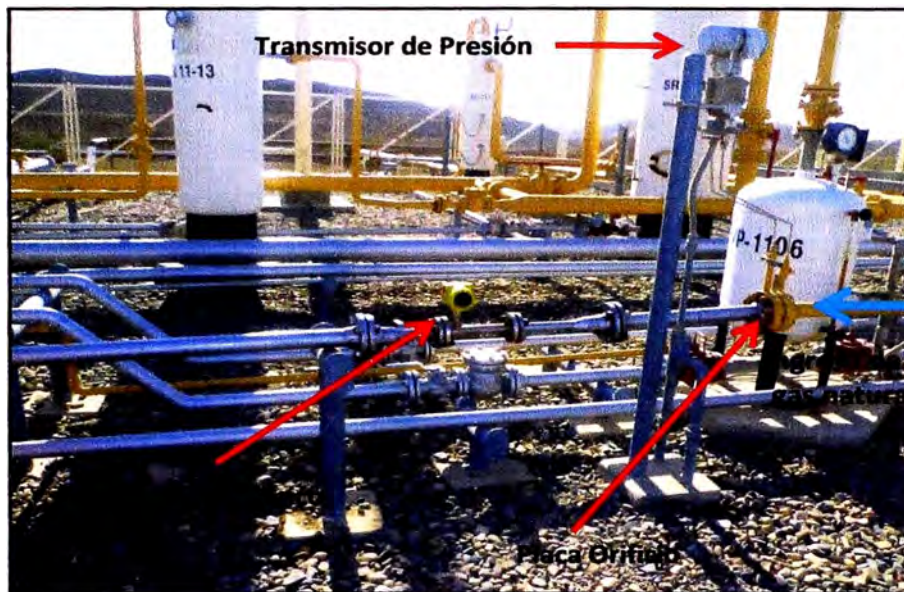

**Fig. 3.1** Diagrama de Proceso dentro de la Batería de Producción

Fuente: Presentación Instalaciones de Superficie - Área de Ingeniería de Producción e Instalaciones – Petrobras Energía del Perú S.A. 2010

### 3.1.2 Condiciones de la Instalación del Puente

En la figura 3.2 se aprecia la instalación típica del Puente de Medición en el Separador de Pruebas:



**Fig. 3.2** Puente de Medición Separador de Pruebas (Fuente: Fotografía de Empresa Petrobras Energía del Perú S.A.)

Como se aprecia en la figura 3.2 se tiene en la parte derecha un sistema de medición que consiste en una placa orificio con un transmisor de presión diferencial. La señal del transmisor de presión diferencial va a un computador de flujo que recoge la señal de todos los transmisores y realiza los cálculos del volumen y caudal de gas de cada tren de medición. Las características técnicas de los equipos que forman parte del actual sistema de medición se presentan con mayor detalle en el Anexo 2 del presente informe.

Se puede apreciar que la longitud del puente de medición es bastante larga con lo cual se puede colocar en serie otro medidor como se puede visualizar.

A continuación se resume en la Tabla 3.1 las condiciones en las que se realiza el proceso de medición. En la Tabla 3.2 encontramos la composición del gas natural de la zona de Órganos (Fuente: Tablas de Producción Petrobras Energía del Perú S.A.)

**Tabla 3.1** Condiciones en las que se realiza el proceso de medición en Separador de Pruebas 5 OR-11

<b>Característica</b>	<b>Valor</b>	<b>Unidad</b>
Presión Manométrica	12 a 15	psi
Temperatura Ambiente	19 a 32	°C
Temperatura del Fluido	15 a 20	°C
Rango Presión Diferencial	0 - 200	inwc
Caudal Gas (estimado)	0 - 100000	SCFD
	0 - 0,016	m <sup>3</sup> /s
Voltaje de Alimentación	24	VDC

**Tabla 3.2** Composición de Gas en la Batería OR-11

<b>Componente</b>		<b>Porcentaje en Moles (%)</b>
Metano	C1	83.238
Etano	C2	6.326
Propano	C3	2.877
Iso-Butano	iC4	1.515
n-Butano	nC4	1.647
Iso-Pentano	iC5	1.234
n-Pentano	nC5	0.809
Hexano +	C6+	1.644
Dioxido Carbono	CO2	0.162
Oxígeno	O2	0.0000
Nitrógeno	N2	0.548

El gas que pasa en el tren de medición es un gas húmedo, ya que a pesar de que se tiene una etapa de separación física, esto no garantiza que dejen de pasar trazas de agua. Esta humedad se debe a las características físicas del pozo, es decir hay pozos que tienen poco porcentaje de agua y otros que tienen mucho. Normalmente en la zona de órganos los pozos tienen una baja

humedad (menor al 20%), sin embargo se tienen gases húmedos aun luego de la etapa de separación primaria.

### 3.1.3 Estado y condición encontrada del dispositivo de Medición de Caudal

Se tiene un Medidor de Presión Diferencial con Placa Orificio como elemento primario en la figura 3.3, donde se muestran los principales parámetros de configuración de la placa orificio actualmente instalada.

Flowrun #3	
Date of last change	2011-10-31 12:27:52
Plate change date	2011-04-15 16:52:59
Flowrun name	SP-1105
Flowrun status	Running
Flowrun type	Gas
Volume, Mass, Energy Calculations	Volume only
Primary Device	Differential Producer
Device type	Orifice meter
Orifice pressure tap type	Flange taps
Orifice tap location	Upstream
Orifice DP stack/check mode	Single
Gas data type	Mole Fractions
Z method in use	AGA8(92) Detailed
Hourly History log size	30 d
Daily History log size	30 d
Qb/press peak logging	Off
Density source	Calculated
Gas component mode	Entered
Gravity mode.	Calculated
Gas component logging	User Change Log
Flowing direction	Forward
Hourly History log interval	60 m
Calculation delay	60 s
Z factor counter	5
Averaging delay	5000 msec
Averaging style	Flowtime
Estimate during plate change	TRUE
Estimation off/on	TRUE
Estimation basis	5 m
Partial records enabled	TRUE
Flow check limit	2.000 %
Calculation Sync Counter	1499116
Z matrix size	Single
Heating value mode	Calculated Hvb (Calculated Hm)
Direction status in (flow / no flow)	NOT ASSIGNED

**Fig. 3.3** Principales parámetros de configuración en el Computador NUFLO 1131C (Fuente: Reporte Snapshot NUFLO 1131 – Petrobras Energía del Perú S.A.)

El Computador de Flujo 1131C de la marca NUFLO, cuyas especificaciones se encuentran en el Anexo 2, tiene la capacidad de generar reportes diarios, por hora, snapshot, alarmas y eventos. Para tener una idea de las actuales

condiciones de la medición se presenta en la figura 3.4 un reporte diario de la medición en el tren de medición del separador de prueba 5 (Fuente: Reporte Snapshot NUFLO 1131 – Petrobras Energía del Perú S.A.)

Daily Flowrun History				2011-12-01 17:34			
Node Name : OR-11-2		Board ID: 10114193					
Flowrun Name : SP-1105 [3]		Version : NFlo M4.3.6R					
Meter ID :		ScanWin : B3.0.0W					
Reporting : 2011-11-01 09:01 to 2011-12-01 09:00		Zone :					
Contract Time : 09:00 hours Report Month : November, 2011							
dr : 0.500 in	Press F.S. : N/A	Gr : 0.682 RDg					
Dr : 2.000 in	Temp. Rng : N/A	Hvb : N/A					
Patm : 14.700 psia	DiffP F.S. : N/A	xc1 : 83.2387					
Pbase : 14.700 psia	DP Cutoff : N/A	xN2 : 0.5477					
Tbase : 60.000 F	Z Mthd. : AGA8(92) Detailed	xcO2 : 0.1615					
Day	Flow Hrs.	Status	Flags	Pressure	Diff. P.	Temp.	Volume
				psia	IwC	F	MCF
1	18.37	E	TGV v	37.20	0.19	60.00	20.31
2	12.51	E	TGV v	37.21	0.22	60.00	14.32
3	12.49	E	TGV v	37.22	0.19	60.00	14.36
4	23.74	E	TGV v	38.25	2.12	60.00	89.49
5	11.69	E	TGV v	34.61	0.37	60.00	14.78
6	11.27	E	TGV v	37.01	0.11	60.00	9.65
7	10.90	E	TGV v	37.29	0.25	60.00	13.43
8	12.95	E	TGV v	37.31	0.37	60.00	19.98
9	20.50	E	TGV v	37.93	1.31	60.00	51.68
10	20.38	E	TGV v	37.41	0.46	60.00	33.20
11	13.99	E	TGV v	37.09	0.11	60.00	8.83
12	19.92	E	TGV v	37.58	0.96	60.00	43.41
13	16.83	E	TGV v	36.87	0.20	60.00	20.19
14	10.75	E	TGV v	37.19	0.15	60.00	8.32
15	9.77	E	TGV v	37.06	0.07	60.00	5.44
16	11.74	E	TGV v	37.84	1.07	60.00	23.44
17	13.05	E	TGV v	37.27	0.27	60.00	16.78
18	12.87	eME C	TGV v	37.46	0.39	60.00	19.89
19	13.30	E	TGV v	37.23	0.31	60.00	17.55
20	18.59	E	TGV v	37.72	1.05	60.00	43.95
21	13.24	E	TGV v	37.20	0.15	60.00	13.84
22	8.60	E	TGV v	37.28	0.12	60.00	7.56
23	10.28	E	TGV v	37.13	0.09	60.00	7.99
24	9.35	E	TGV v	37.12	0.08	60.00	6.92
25	9.54	E	TGV v	37.00	0.08	60.00	7.05
26	19.04	E	TGV v	37.29	0.40	60.00	29.22
27	13.68	E	TGV v	37.14	0.15	60.00	13.86
28	1.68		TGV v	37.09	0.13	60.00	1.64
Flowing Average:				37.29	0.51	60.00	36.35
Totals: 381.02							577.08
Legend:							
p - partial	F - Flowrun alarms	T - Temp. non-live value					
e - estimation	C - Check alarms	G - Gr non-live value					
M - Memory Fault	1 - Status #1	V - Hv non-live value					
E - Events occurred	2 - Status #2	^ - ScanBase edited val.					
U - User changes occurred	D - DP Default / MVX Alarm	* - (a)larm,(v)alid,(f)inal					
H - Hardware out of range	P - SP non-live value						

Cabe resaltar que los valores tanto de presión diferencial, temperatura y presión estática son valores promedio ya que como se observará cuando se analicen en el capítulo 5 los datos de los pozos de prueba, los mismos son

muy variables (0 a 100000 SCFD – aproximadamente 0 – 1401 m<sup>3</sup>/día para las condiciones de presión y temperatura establecidos)

#### **3.1.4 Análisis de las fuentes del error encontrado en la medición del caudal de gas**

Como se apreció anteriormente se tienen unas condiciones de flujo variables y esto ocasiona que el rango de medición de la placa orificio actualmente instalada no permita realizar mediciones en rangos más allá de capacidad.

Para poder establecer el rango de caudales en los cuales se puede afirmar que la medición es confiable, se aplicará el cálculo de incertidumbre analizado en el Capítulo 2 basado en la Norma ISO 5167.

Los resultados de los análisis realizados se muestran a continuación en la tabla 3.3. (Elaboración Propia) Cabe resaltar que la incertidumbre calculada por la ISO 5167 es respecto al caudal medido y no al span del caudalímetro.



**Tabla 3.3:** Valores de Caudal permisible para la Placa Orificio ( $\beta=0,25 - D=2''$ )

Caudal (SCFD)	Caudal (SCFH)	Error Placa Orificio (ISO5167) (%)		Presión Diferencial		Reynolds
		Sin Transmisor DP	Con Transmisor DP	inwc	psi	
9000	375.00	0.87	0.92	1.015	0.0366	5019
9500	395.83	0.87	0.91	1.133	0.0409	5298
10000	416.67	0.87	0.9	1.256	0.0453	5577
10500	437.50	0.87	0.9	1.386	0.0500	5855
11000	458.33	0.87	0.89	1.523	0.0549	6134
11500	479.17	0.87	0.89	1.666	0.0601	6413
12000	500.00	0.87	0.89	1.816	0.0655	6692
12500	520.83	0.87	0.89	1.972	0.0711	6971
13000	541.67	0.87	0.88	2.134	0.0770	7250
13500	562.50	0.87	0.88	2.303	0.0831	7528
14000	583.33	0.87	0.88	2.478	0.0894	7807
14500	604.17	0.87	0.88	2.66	0.0960	8086
15000	625.00	0.87	0.88	2.849	0.1028	8365
15500	645.83	0.87	0.88	3.044	0.1098	8644
16000	666.67	0.87	0.88	3.245	0.1171	8923
16500	687.50	0.87	0.91	3.453	0.1246	9201
17000	708.33	0.87	0.9	3.667	0.1323	9480
17500	729.17	0.87	0.9	3.888	0.1403	9759
18000	750.00	0.87	0.9	4.116	0.1485	10038
18500	770.83	0.87	0.9	4.35	0.1569	10317
19000	791.67	0.87	0.89	4.591	0.1656	10596
19500	812.50	0.87	0.89	4.838	0.1745	10874
20000	833.33	0.87	0.89	5.091	0.1837	11153
20500	854.17	0.87	0.89	5.352	0.1931	11432
21000	875.00	0.87	0.89	5.618	0.2027	11711
21500	895.83	0.87	0.89	5.892	0.2126	11990
22000	916.67	0.87	0.89	6.172	0.2227	12269
22500	937.50	0.87	0.88	6.458	0.2330	12547
23000	958.33	0.87	0.88	6.751	0.2435	12826
23500	979.17	0.88	0.88	7.051	0.2544	13105
24000	1000.00	0.88	0.88	7.357	0.2654	13384
24500	1020.83	0.88	0.88	7.67	0.2767	13363
25000	1041.67	0.88	0.88	7.99	0.2882	13942
25500	1062.50	0.88	0.88	8.316	0.3000	14220
26000	1083.33	0.88	0.88	8.649	0.3120	14499
26500	1104.17	0.88	0.88	8.989	0.3243	14778
27000	1125.00	0.88	0.88	9.335	0.3368	15057
27500	1145.83	0.88	0.88	9.688	0.3495	15336
28000	1166.67	0.88	0.88	10.048	0.3625	15614
28500	1187.50	0.88	0.88	10.414	0.3757	15893
29000	1208.33	0.88	0.88	10.787	0.3891	16172
29500	1229.17	0.88	0.88	11.167	0.4028	16451
30000	1250.00	0.88	0.88	11.553	0.4168	16730
30500	1270.83	0.88	0.88	11.946	0.4310	17009
31000	1291.67	0.88	0.88	12.346	0.4454	17287
31500	1312.50	0.88	0.88	12.753	0.4601	17566
32000	1333.33	0.88	0.88	13.167	0.4750	17845
32500	1354.17	0.88	0.88	13.587	0.4902	18124
33000	1375.00	0.88	0.88	14.014	0.5056	18403

Como se aprecia en la tabla 3.3 los valores de caudal son entre 9000 y 33000 SCFD. Esto se debe a 2 factores principales:

1<sup>ro</sup> Debido al valor de  $\beta = 0,25$  se tiene que por debajo del valor de 9000 SCFD el valor de la velocidad del fluido (y por ende el Número de Reynolds) es muy bajo para poder establecer una presión diferencial detectable por el instrumento.

2<sup>do</sup> Se aprecia en la tabla 3.3 que el valor de caída de presión es de 0,5056 psi y se toma esto como el valor máximo para la caída de presión ya que como se especificó anteriormente la presión de trabajo es 15 psi. Como se apreció al inicio de la descripción del proceso el gas medido pasa a la estación de compresores, la cual en el caso de OR-11 se encuentra a unos 5 km y a una altura superior. Por lo tanto para evitar que gane la contrapresión de la línea se ha definido la caída de presión de 0,5 psi como la máxima permisible.

## **3.2 Selección de Tecnología a Utilizar**

### **3.2.1 Características requeridas para Dispositivo de Medición**

Como consecuencia de los rangos altamente variables de presión, temperatura y principalmente de caudal, se hace necesario seleccionar un dispositivo de medición cuyas características mínimas sean las indicadas en la tabla 3.4:

**Tabla 3.4** Características Mínimas requeridas para caudalímetro de Medición de Gas en Tren de Medición 5 Batería OR-11

<b>Característica</b>	<b>Valor</b>	<b>Unidad</b>
Presión de Trabajo	15 – 20	psi
Temperatura de Trabajo	60 – 100	°F
Caudal de Trabajo	0 - 100000	SCFD
Rangeabilidad	100:1	
Máxima Presión Diferencial	0,5	psi
Exactitud mínima aceptable	1	% de lectura
Repetibilidad	1	% de span
Diámetro Tubería	2	pulgada
Material requerido	Acero Inoxidable 316	
Schedule	40	
Tipo de Conexión	Bridada	
Tensión de Alimentación	24	VDC
Máxima Potencia Disipada	10	W
Tipo de Salida	4-20	mA
Grado de Protección	IP67 o NEMA 4	

Se especifica una tensión de 24 VDC ya que se dispone de un tablero de control con esta tensión en sus borneras de salida. Además en dicho tablero se contempla una entrada analógica de 4 a 20 mA para la lectura en línea del valor de caudal instantáneo.

Se ha fijado el grado de protección en IP67 debido a las condiciones climáticas presentes, como se aprecia en la figura 6 el sistema está a la intemperie y en pleno desierto. Por ello es susceptible a la acumulación de polvo y caída de precipitaciones en los meses de verano (aun mayor el efecto si hay Fenómeno del Niño)

### 3.2.2 Selección de Tecnología de Medición

De acuerdo a las características presentadas en la Tabla 3.4 se requiere un dispositivo con un amplio rango de medición y una baja caída de presión, sobre todo en el punto de máximo caudal ya que en este punto ocurre la máxima caída de presión- A continuación en la Tabla 3.5 se comparan las tecnologías de los medidores de placa orificio y dispersión térmica lo que permitirá la selección del medidor más adecuado.

**Tabla 3.5** Comparación de Características Principales del medidor con placa orificio y de dispersión térmica

Característica	Principio de Medición Elemento Primario		Unidad
	Placa Orificio	Dispersión Térmica	
Presión de Trabajo	0 -6300	0 -240	psi
Temperatura de Trabajo	-328 - 1830	0 – 250	°F
Caudal de Trabajo	9000 - 100000	100 – 100000	SCFD
Rangeabilidad	3:1	100:1	
Máxima Presión Diferencial	5,095	0,145	psi
Exactitud Nominal	1,5 (Lectura)	0,5 (Full Scale) – 1 (Lectura)	%
Repetibilidad	No especifica	0,5	%
Diámetro Tubería	3/8 - 40	1/4 – 2	pulgada
Material requerido	Acero Inoxidable 316	Acero Inoxidable 316	
Schedule	40	40	
Tipo de Conexión	Bridada	Bridada	
Tensión de Alimentación	24	24	VDC
Máxima Potencia Disipada	10	10	W
Tipo de Salida	4 - 20	4 - 20	mA
Grado de Protección	IP 67	IP 67	

Como se aprecia en la tabla 3.5 tanto las características de protección, alimentación eléctrica y material son similares. Por ello se centrará la elección en las características metrológicas de los equipos.

Se aprecia que los rangos de trabajo en presión y temperatura de la placa orificio son mayores que el caudalímetro por dispersión térmica (máscico térmico) Sin embargo debido a las características del proceso, prácticamente esto no es significativo ya que como se indicó en la figura 7 los rangos de presión y temperaturas son poco variables llegando como máximo a 15 psi.

La diferencia entre la performance de uno y otro equipo se aprecia en los caudales manejados y las incertidumbres en la medición encontradas. Debido al principio de Dispersión Térmica explicado en el anterior capítulo, el caudalímetro máscico térmico puede medir caudales en un rango comprendido entre 100 a 100000 SCFD con una mayor exactitud (1 vs. 1,5 % de la Placa Orificio)

Sin embargo el factor determinante es la poca caída de presión del dispositivo ya que aun con el máximo caudal su caída de presión es apenas 0,145 psi que es mucho menor a los 5 psi de la placa orificio. Se debe resaltar la importancia de este punto ya que se tiene una presión de trabajo de 15 psi y luego el gas pasa a las estaciones de compresión que se encuentran distantes y a una mayor altura.

Por lo anteriormente expuesto se elegirá el Caudalímetro Másico Térmico para realizar las pruebas piloto de medición.

### 3.3 Especificación del Dispositivo a utilizar

El dispositivo de Medición a utilizar será el Caudalímetro Másico Térmico de la Marca Endress Hauser Modelo ST-75V. Las principales características y vistas del equipo se presentan en la Tabla 3.6.



**Fig. 3.5** Vista interna de caudalímetro ST-75V



**Fig. 3.6** Vista de datos de placa caudalímetro ST-75V

**Tabla 3.6** Principales especificaciones de caudalímetro ST-75V (Fuente: ST 75V

Datasheet – Anexo 3)

<b>Instrumento</b>	
Fluidos Compatibles	Aire, Aire Comprimido, Nitrógeno, Oxígeno, Argón, CO <sub>2</sub> , Ozono, Gases Inertes, Gas Natural, Hidrógenos
Conexión a Proceso	Rosca Hembra NPT, Rosca Macho NPT, Brida ANSI o DIN
Diámetro	1"
Caudal de Trabajo	100 - 100000 SCFD (Para el Modelo Escogido)
Rangeabilidad	100:1
Exactitud	± 1% de Lectura, 0,5% de Full Scale
Repetibilidad	± 0,5% de Lectura
Máxima Presión Diferencial	0,145
Exactitud Nominal	0,5 %(Full Scale)
<b>Elemento Primario</b>	
Tipo	Medidor de Inserción (Sondas)
Material de Construcción	Acero Inoxidable 316
Material Termopozo (Sonda)	Hastelloy-C
Máxima Presión de Operación	240 psi (16,5 bar)
Temperatura de Trabajo	0 - 250 °F ( -18 -121 °C)
<b>Alimentación</b>	
Tensión de Alimentación	18 - 36 VDC
Máxima Potencia Disipada	6 W
<b>Transmisor</b>	
Tipo de Salida	4 - 20 mA (Caudal Instáneo), 0-1000Hz para Volumen
Grado de Protección	IP 67
Puerto de Comunicación	RS-232
Temperatura de Trabajo	0 - 140°F ( -18 - 60°C)
Display Digital	Pantalla LCD de 2 líneas x 16 caracteres. Caudal instantáneo en línea superior, segunda línea asignable por el usuario.

Como se aprecia en la figura 3.5 la razón de la baja caída de presión en el equipo es debido a que la interferencia con el flujo de las sondas es poco significativa a comparación de la obstrucción ocasionada con la placa orificio.

Un aspecto que se debe tener en cuenta en la instalación de este dispositivo son los diámetros aguas arriba y aguas abajo que se deben considerar para la longitud de la tubería. Según la recomendación del fabricante este deberá ser veinte diámetros aguas arriba y diez diámetros aguas abajo. Es decir en el caso particular del caudalímetro seleccionado las distancias aguas arriba y aguas abajo serán veinte y

diez pulgadas respectivamente. Todas las especificaciones y manuales del equipo seleccionado se presentan en el Anexo 3.

En el presente capítulo se documenta como se ha seleccionado la tecnología de dispersión térmica para las pruebas a realizarse en el Separador 5 de la Batería OR-11, dicha tecnología consiste en la medición de caudal por la transferencia de calor entre el fluido y la sonda insertada.



# **CAPÍTULO IV**

## **INSTALACIÓN COMPONENTES PUENTE DE MEDICIÓN**

### **4.1 Instalación Mecánica de Dispositivo**

#### **4.1.1 Características Mecánicas**

Se especificó en el punto 3.3 que el caudalímetro másico térmico seleccionado requiere tener veinte diámetros aguas arriba sin obstrucciones y diez diámetros aguas abajo. Se debe recordar que la tubería donde se encuentra el puente de medición es de 2 pulgadas, mientras que el caudalímetro es de 1 pulgada. Por este motivo se requiere la instalación de reducciones de 2"X1" a las distancias señaladas.

Inicialmente se previó instalar un acondicionador de flujo VORTAB, sin embargo dada la longitud de la línea no se llegó a instalar.

#### **4.1.2 Plano de montaje**

En los planos anexados al informe se muestra el de montaje mecánico del caudalímetro, el cual consiste en el tren de medición instalado con las respectivas reducciones. Se aclara que el tipo de Brida es ANSI 150 debido a la baja presión que soporta la línea (15 a 20 psi)

### **4.2 Instalación eléctrica del dispositivo**

#### **4.2.1 Características eléctricas**

Tal como se describió en la sección anterior el dispositivo soporta una alimentación de 18 a 36 VDC. Esta alimentación se tomará del tablero de control ABB que realiza el monitoreo y control de los volúmenes de las baterías.

El cable estándar de alimentación para las baterías y de acuerdo a las especificaciones es 16 AWG.

#### **4.2.2 Diagrama Unifilar**

En los planos anexados se muestra el diagrama unifilar desde la alimentación de la SubEstación (480VAC) hasta la alimentación propia del caudalímetro (24VDC). En el primer plano se aprecia la alimentación desde la Subestación de la Batería OR-11 hasta la alimentación al tablero de control ABB. En el segundo plano se muestra la alimentación del tablero ABB hacia el caudalímetro y se considera además la alimentación para más caudalímetros, ya que el objetivo es luego de las pruebas piloto la masificación de estos dispositivos.

### 4.3 Parametrado de dispositivo

#### 4.3.1 Parámetros de Medición

Como se ha explicado anteriormente el caudalímetro másico térmico ST-75V tiene una exactitud nominal de 0,5% de la escala completa, es decir 1% de Valor leído. Antes de la realización del montaje y pruebas en campo, se realizó en fábrica la calibración del dispositivo cuyos resultados se muestran en la figura 4.1

Se aprecia que la calibración en fábrica se realizó con una tobera especialmente diseñada para la medición de Gas. Nótese que el máximo error del instrumento es 1,22% de la lectura (1072 SCFH), es decir 25728 SCFD. El resto de errores es menor al 1% y es en bajo caudal donde se quiere la mejor performance del equipo ya que como se vio en el acápite 3.1.4, la placa orificio puede manejar el rango medio del espectro de caudal requerido

En la figura 4.2 se presenta la Hoja de Calibración de la salida analógica del caudalímetro. Se aprecia que el error máximo presentado es:

$$Error \ I \ \% = \frac{I_{instrumento} - I_{referencia}}{I_{m\acute{a}x} - I_{m\acute{i}n}} 100\%$$

Reemplazando los respectivos valores obtenemos:

$$Error \ (I)\% = 0,65\%$$

Este error es bajo ya que apenas se influencia  $0,06\Omega$  en el valor de la resistencia y 32 mV en la salida de tensión, con lo cual se puede afirmar que el caudal a contabilizarse por un Sistema SCADA no se verá alterada con respecto al dato observado en campo. Para una evaluación final de la exactitud en el SCADA se deberá tomar en cuenta las incertidumbres en los módulos analógicos del tablero de control.

# FCI FLUID COMPONENTS INTERNATIONAL LLC

A Limited Liability Company - [www.fluid-components.com](http://www.fluid-components.com)  
1755 La Costa Meadows Drive, San Marcos, CA 92078-5115  
(760)744-6950 (800)854-1993 FAX: (760)736-6250

## Model ST75V Flowmeter

### CALIBRATION CERTIFICATE

#### PROYECTOS / PETROBRAS

<b>Customer Order Number:</b>	C051999	<b>Part Number:</b>	ST75V-2G1GF1GPT0
<b>Serial Number:</b>	336353	<b>PCI Calibration Procedure:</b>	19EN000018 Rev. NC
<b>Purchase Order Number:</b>	6550-4RVO-1111	<b>Local Tag #1:</b>	N/A
<b>Customer Flow Range:</b>	42.5 to 4250 SCFH	<b>Local Tag #2:</b>	N/A
<b>Customer Line Size:</b>	1.049 inches i.d. 1 inch sch. 40	<b>Local Tag #3:</b>	N/A
<b>Customer Temperature Range:</b>	25 to 50 deg C	<b>Remote Tag #1:</b>	N/A
<b>Customer Pressure Range:</b>	0 to 30 psig	<b>Remote Tag #2:</b>	N/A
<b>Customer Installation:</b>	Orientation Code G	<b>Remote Tag #3:</b>	N/A
<b>Customer Standard Conditions:</b>	70 deg F and 14.7 psia		
<b>Customer Actual Media:</b>			Natural Gas: Methane 90%, Ethane 10% (Volume%)
<b>PCI Calibration Media:</b>			Methane 100%

#### Output Information

**Output #1:** 4-20 mA = 0 to 4250 SCFH  
**Calibration Equation:** SCFH = 265.6 x mA - 1063  
(step = 42.5 SCFH @ 4 mA)

**Output #2:** 4-20 mA = 0 to 150 Deg F  
**Temperature Equation:** Deg F = 9.375 x mA - 37.50  
(Based on manufacturer's recommended temperature vs. resistance equation)

#### Calibration Notes

- Calibration performed using equipment traceable to N.I.S.T. (U.S. National Institute of Standards and Technology).
- Substitute gas and gas equivalency used for calibration.
- VORTAB Calibration.

#### Final Flow Verification performed on Gas Sonic Nozzle Stand

Desired SCFH Per Stand	Model ST75V Indicated SCFH	Actual % Reading Difference	Allowed % Reading Difference
1072	1085	-1.22	=2.98
2128	2131	-0.15	=2.00
3174	3164	-0.30	=1.67
4237	4224	-0.30	=1.50

#### N.I.S.T. Traceable Equipment: Gas Sonic Nozzle Stand

Calibration Control Number	Calibration Date	Calibration Due date	Equipment Description
EL-579	30-Apr-10	30-Apr-11	HP Data Acquisition Unit
FM-081	2-Dec-09	2-Dec-11	Sonic Nozzle (0.0225")
FM-091	9-Apr-10	9-Apr-12	Sonic Nozzle (0.054")
FM-092	9-Apr-10	9-Apr-12	Sonic Nozzle (0.125")
FM-093	10-Apr-10	10-Apr-12	Sonic Nozzle (0.298")
FM-118	1-Dec-09	1-Dec-11	Sonic Nozzle (0.01")
PG-168	9-Nov-10	9-May-11	Pressure Transducer
PG-220	9-Nov-10	9-May-11	Pressure Transducer
PG-221	3-Nov-10	3-Nov-11	Pressure Transducer
TE-009	6-May-10	6-May-11	RTD (T.I.)
TE-010	6-May-10	6-May-11	RTD (Nozzle)

Technician: P. Bell 210  
Calibration Date: 7-Jan-11

Fig. 4.1 Certificado de Calibración (Fábrica) para Caudalímetro Másico  
Térmico (Fuente: Fluid Components Internacional)

C#:		Serial:		Dec-Box	Equip.	Cal. Due
C052999		336353				
Cust.:		Date:		(Act.)		
PROYECTOS /		January 10, 2011		EL-515	20-Jan-11	
Tag:		TagR1:		(Ref)		
N/A		N/A		EL-318	04-Nov-11	
TagL2:		TagR2:		DVM:		
N/A		N/A		EL-302	03-Sep-11	
TagL3:		TagR3:		250 ohm:		
N/A		N/A		EL-412	18-Feb-11	

Nominal Sensor Resistance:	1000 Ω
Indicated Temperature at Nominal Resistance:	31.30 F

Notes:	ST75V, calibration group 1.
--------	-----------------------------

Test Tech.:	223
-------------	-----

Delta 'R (ohms)	VDC Output	mA Output	Unit dR	Indicated Display
131.87	1.000	4.00	131.984	0.000 SCFH
129.87	1.040	4.16	129.996	43.34 SCFH
71.95	1.996	7.98	72.126	1060 SCFH
63.11	2.994	11.98	63.302	2120 SCFH
58.73	3.986	15.94	58.920	3181 SCFH
56.06	4.968	19.87	56.251	4218 SCFH

EPROM Information	
Version	5.05
Date	8/14/2009
Checksum	N/A

Cust Flow Data		dR Mn		TSpanDac0	
SW Version	5.05	5E 580001		3285	
Flow Factor	21.60632E	dR Max	137.00000	TZeroDac0	663
Cminflow	0.000000	CaRe <sup>2</sup>	1080.1700	TSpanDac1	3272
Cmaxflow	4250.000E	Tcsp	0.0005824	TZeroDac1	652
Eng Units	SCFH	Tcsp0	0.000000	<b>Switch Pts</b>	
LineSize0	1.0490000	Tcsp2	0.000000	State 0	High to Low
LineSize1	0.000000E	<b>Totalizer/Pulse Output</b>		Switchpt0	0.000000
CminTemp	0.000000	Tot Menu	OFF	State 1	High to Low
CmaxTemp	150.00000	Tot Flag	OFF	Switchpt1	0.000000
<b>Cal Flow Data</b>		Totalizer	0.000000	<b>Misc</b>	
MinFlow	1.568890E	Roller Cnt	0	KFactor1	0.000000
MaxFlow	236.02679	Flt Flag	OFF	KFactor2	1.000000
Std. Dens.	0.045246E	Pulse Factor	1.000000	KFactor3	0.000000
C1[1]	2.89804601E	Pulseout	Src P1   Slnk P1	KFactor4	0.000000
C1[2]	-7.568710784	Hours	0	I Factor	-0.067567
C1[3]	781.334777824	Sample Period	1.000000	Temp Flag	ON
C1[4]	-37382.371093	<b>CB Setup</b>		Outmode	mA Flow   mA Temp
C1[5]	6962.75097656	dR Slope	0.0276752	Bexcar max	100
Breakpt	80.330001	dR Offset	-0.637534	RTD SLP	385
C2[1]	52.264835168	Ref Slope	0.5540166	% of Reading	OFF
C2[2]	-274.7279664	Ref Offset	2.2160666	LCD Multiplier	
C2[3]	55266.0117167	SpanDac0	3285	User Name	FCI
C2[4]	-4992581.000E	ZeroDac0	663	Shop Order#	C052999
C2[5]	170130E.0000	SpanDac1	3272	Serial#	336353
		ZeroDac1	652	Model	0

**Fig. 4.2** Hoja de Calibración (Fábrica) de Salida Analógica de Caudal (Fuente: Fluid Components Internacional)

En el presente capítulo queda documentado la manera como se ha implementado un Sistema mejorado de Medición de Gas con un Caudalímetro Másico Térmico en el Separador de Pruebas 5 de la Batería OR-11, por ello se presentaron los respectivos planos y hojas de calibración realizadas en la misma fábrica del caudalímetro.

## **CAPÍTULO V**

### **PUESTA A PUNTO DE LÍNEA DE MEDICIÓN DE GAS**

#### **5.1 Requisitos para pruebas con línea de medición**

##### **5.1.1 Normatividad**

La normatividad utilizada que se tomará en cuenta para las pruebas piloto serán las siguientes:

- ISO 5167

Se utiliza esta norma para el cálculo de la incertidumbre en la placa orificio. El procedimiento puede ser visto en el Capítulo 2.

- AGA 8

Esta norma de la American Gas Association permite el cálculo del Factor de Compresibilidad ( $k$ ) así como su respectiva incertidumbre asociada. Específicamente en la página cuatro de la norma se expone que de acuerdo a las condiciones de proceso del tren de medición estudiado, la incertidumbre esperada es 0,1% como se aprecia en la figura 5.1.

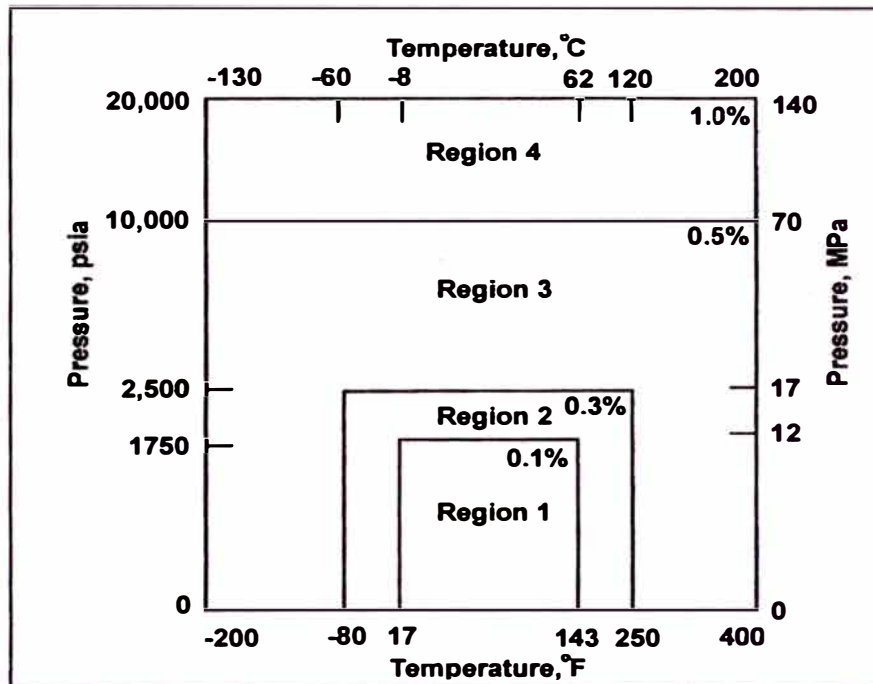

**Fig. 5.1** Máxima Incertidumbre esperada utilizando el Método detallado de Cálculo del AGA 8 (Fuente: AGA 8 – Compressibility Factors of Natural Gas and Other Related Hydrocarbon Gases)

### 5.1.2 Datos requeridos para prueba

Se tendrá en cuenta los siguientes aspectos para las pruebas en campo:

1<sup>ro</sup> En la Tabla 3.5 se aprecia los valores permisibles donde el valor de caudal calculado a partir de la medición de la placa orificio es confiable: 9000 a 33000 SCFD. Esto se utilizará como base para las pruebas, es decir se realizará la comparación de valores entre el caudalímetro másico térmico instalado y la placa orificio ya instalada anteriormente, ambas en la misma línea de medición.



2<sup>do</sup> El valor máximo aceptable de desviación es el 1% del Span del caudalímetro másico térmico, es decir:

$$Tolerancia\ Máxima = \frac{102000 - 1020}{100} SCFD = 1009,8 SCFD$$

3<sup>ro</sup> Luego de validar el rango comparable entre ambos medidores, se analizarán los valores menores a 9000 SCFD. En el caso del primer intervalo se realizará una comparación simulada con una placa orificio, ya que en la práctica como se explicó en capítulos anteriores no se puede implementar esta solución.

### **5.1.3 Formato de Pruebas**

El formato de pruebas que se presenta en la página siguiente proviene del estándar PE-0076 Mantenimiento de Instrumentos que es Estándar Interno de Petrobras. El mencionado formato está basado en las recomendaciones de la Norma ISA 37.11

Se aprecia en el formato las principales características del equipo y el proceso, así como las respectivas fechas y horas de la toma de datos. Un punto importante es que se tendrán dos formatos llenados luego debido a que se tomarán 2 rangos de medición:

- Rango 1:

Caudales dentro del rango válido de medición de la Placa Orificio (9000 a 33000 SCFD) Sólo en este caso será la comparación válida para determinar la exactitud del caudalímetro másico térmico.

- Rango 2:

Caudales menores a 9000 SCFD. Este último rango es el más importante en el estudio ya que hasta el momento no se puede medir con una buena exactitud los caudales de los pozos en este rango. Aproximadamente el 50% de los pozos del Lote X tienen este caudal de gas asociado.

## **5.2 Pruebas Operacionales con Dispositivo de Medición**

### **5.2.1 Resultados Obtenidos**

En el Anexo 4 se aprecian los formatos de verificación ya llenados, cuyos datos presentan las siguientes características:

- Rango 1 ( $9000 \leq Q \leq 33000$  SCFD)

Se tiene un total de 42 puntos de medición. Se realizaron un promedio de 6 a 7 medidas, siendo la medida de cada día señalado de un pozo diferente. En la tabla 5.1 se presentan los valores obtenidos en la pruebas de campo y en la Tabla 5.2 se muestran los resultados de la obtención del promedio y desviación estándar obtenidos.

**Tabla 5.1** Valores obtenidos en las Pruebas de Campo - Rango I

<b>N°</b>	<b>Fecha</b>	<b>Hora</b>	<b>Valor Instantáneo Máximo Térmico (SCFD)</b>	<b>Error Span (%)</b>
1	07/03/2012	15:00	9715	0.29
2	07/03/2012	15:05	10830	0.79
3	07/03/2012	15:10	12061	0.36
4	07/03/2012	15:15	14537	0.01
5	07/03/2012	15:20	14820	0.00
6	07/03/2012	15:25	18583	0.02
7	14/03/2012	15:00	19029	0.04
8	14/03/2012	15:05	23228	0.06
9	14/03/2012	15:10	23918	0.09
10	14/03/2012	15:15	26113	0.02
11	14/03/2012	15:20	26327	0.05
12	21/03/2012	15:20	14912	0.82
13	14/03/2012	15:25	14249	0.01
14	21/03/2012	15:00	20525	3.04
15	21/03/2012	15:05	26213	0.11
16	21/03/2012	15:10	26403	0.09
17	21/03/2012	15:15	29174	0.09
18	21/03/2012	15:25	14133	4.47
19	04/04/2012	15:00	11601	0.95
20	04/04/2012	15:05	11269	0.07
21	04/04/2012	15:10	11964	0.16
22	04/04/2012	15:15	12140	0.00
23	04/04/2012	15:20	17879	0.80
24	04/04/2012	15:25	11132	0.02
25	11/04/2012	15:00	11158	0.03
26	11/04/2012	15:05	12154	0.69
27	11/04/2012	15:10	13283	0.64
28	11/04/2012	15:15	25274	0.12
29	11/04/2012	15:20	26923	0.01
30	18/04/2012	15:25	9868	0.42
31	11/04/2012	15:25	13634	1.33
32	18/04/2012	15:00	12703	0.27
33	18/04/2012	15:05	13634	0.80
34	18/04/2012	15:10	13473	0.02
35	18/04/2012	15:15	19692	5.01
36	18/04/2012	15:20	19408	0.35
37	25/04/2012	15:00	11456	1.60
38	25/04/2012	15:05	11135	0.30
39	25/04/2012	15:10	16571	2.09
40	25/04/2012	15:25	16050	0.75
41	25/04/2012	15:15	16603	0.99
42	25/04/2012	15:20	20615	0.17

**Tabla 5.2** Promedios y desviaciones en comparación de caudalímetros  
- Rango 1

<b>Promedio</b>	0.666 %
<b>Desviación Estándar</b>	1.117 %
<b>Valor Mínimo</b>	0.000 %
<b>Valor Máximo</b>	5.012 %

Se aprecia que el promedio de desviaciones es menor al 1% del span, es decir la diferencia entre el valor medido por la placa orificio y el valor medido por el caudalímetro másico térmico es menor o igual a 1009,8 SCFD. Se observa además que 36 de los 42 registros tienen un valor de error menor al 1%. El análisis de los datos se realizará en la sección siguiente.

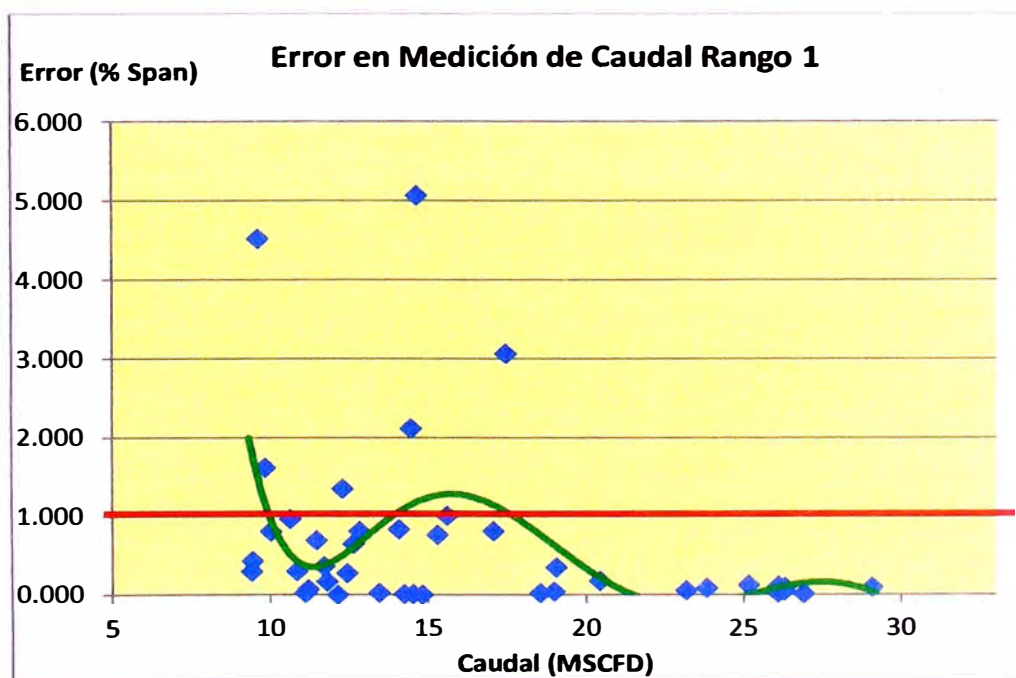

**Fig 5.2** Gráfico comparativo de error en Medición para el Rango 1

- Rango 2 ( $Q \leq 9000$  SCFD)

Se tiene un total de 23 puntos que se muestran en la tabla 5.2:

**Tabla 5.2** Promedios y desviaciones en comparación de caudalímetros

- Rango 2

Propiedad	% de Lectura	% de Span
Máxima Desviación(%)	6269.727	20.489
Mínima Desviación(%)	10.333	0.275
Promedio de Desviaciones	802.958	6.817

Se aprecia que sólo 4 valores analizados se encuentran con una diferencia menor al 1% del span entre la medición del caudalímetro másico térmico y la supuesta medición de la placa orificio. Recordemos que la placa instalada no puede medir un caudal menor a 9000 SCFD debido a la poca presión diferencial generada.

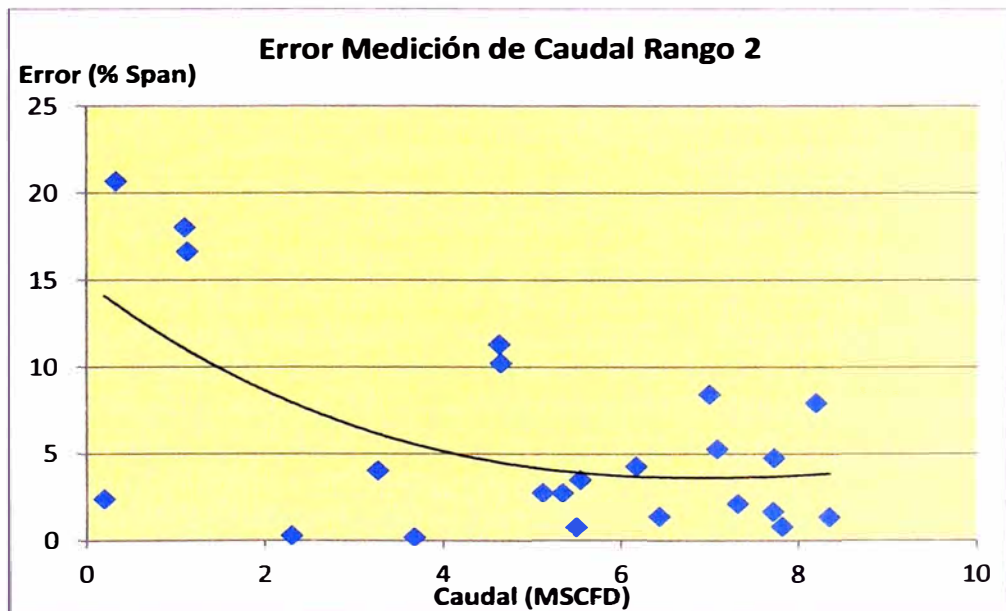

**Fig 5.3** Gráfico comparativo de error en medición para el Rango 2

### 5.2.2 Análisis metrológico de resultados

Se analizarán los resultados obtenidos en cada rango:

- Rango 1 ( $9000 < Q < 33000$ )

Se aprecia en la figura 5.3 que existe una tendencia decreciente del error conforme va aumentando flujo del gas. Sin embargo como se indicó en la sección 5.2.1, seis de los puntos se encuentran con un error mayor al 1% del span del caudalímetro másico térmico.

Sin embargo para poder establecer la validez de la medición, es decir que el promedio de las desviaciones es menor al 1%, se plantea la siguiente hipótesis:

Hipótesis Nula ( $H_0$ )

$$\text{Promedio } E \leq 1\%$$

Hipótesis Alternativa ( $H_1$ )

$$E > 1\%$$

$\alpha = 0.05$  (Error Tipo I, Aceptar  $H_1$  cuando  $H_0$  es cierto)

Para la prueba de hipótesis se asumirá que la probabilidad de ocurrencia de las variables sigue una distribución binomial, lo cual es razonable ya que tenemos 42 muestras de una población (también por eso se calcula la desviación estándar poblacional)

Para calcular el estadístico de prueba utilizamos la siguiente fórmula:

$$Z_{prueba} = \frac{E - E_{esperado}}{\left(\frac{\sigma}{N}\right)}$$

Para un mejor análisis se grafica nuevamente el Error vs. Caudal para los puntos con un error mayor al 1%.

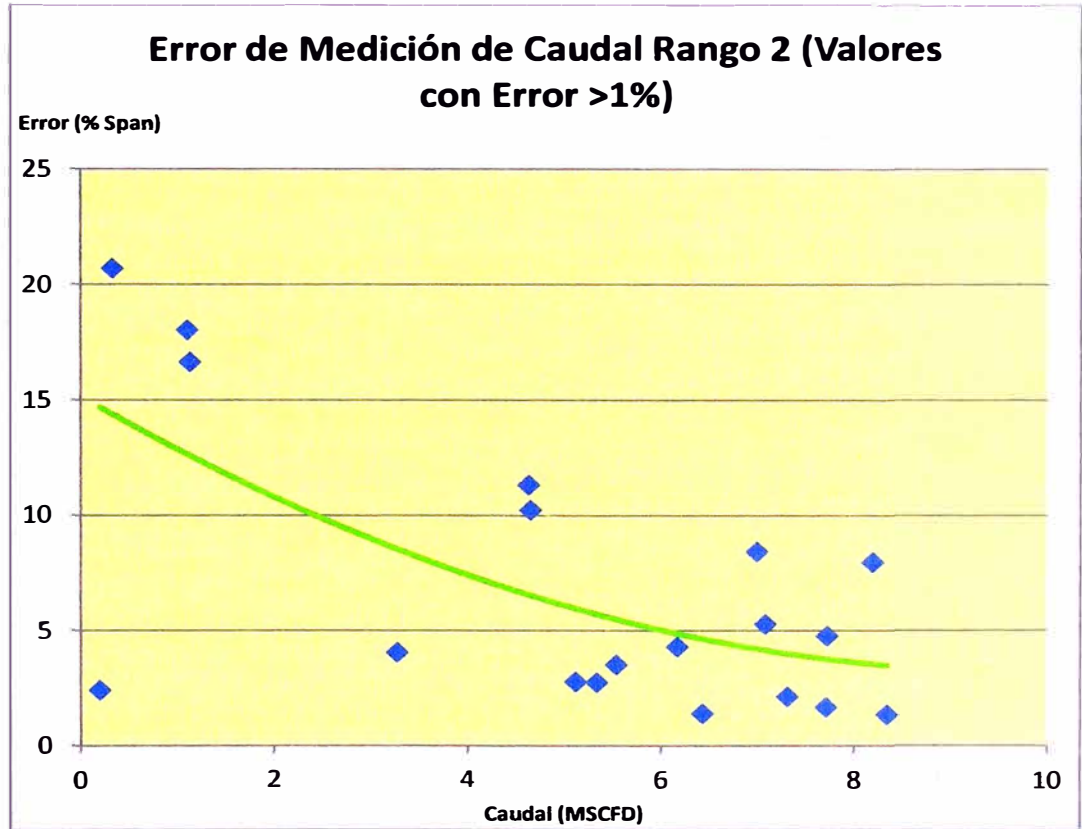

**Fig. 5.6** Gráfico de Error para Rango 1 para puntos con Error menor al 1%

Se aprecia claramente una tendencia decreciente de la diferencia conforme el caudal va aumentando a 9000 SCFD. Como se puede ver la diferencia puede llegar hasta más del 20% del span, es decir 20400 SCFD, lo cual naturalmente hace que la placa orificio no sea un medidor adecuado para la línea de gas instalada.

En el presente capítulo se demostró que la precisión del caudalímetro másico Térmico se encuentra dentro del 1% del Span de Medición en el rango de 9000 a

Donde:

$\sigma$ : Desviación Estándar

$N$ : Tamaño de la Muestra

$E_{esperado}$ : Valor Promedio de prueba

$E$ : Valor promedio obtenido de muestra

Reemplazando los valores respectivos se obtiene:

$$Z_{prueba} = -1.94$$

Entonces el valor del estadístico con un Nivel de Significación de 0.05

es: 1.64

Se aprecia que:

$$Z_{prueba} < Z_{alfa}$$

Por lo tanto se acepta  $H_0$  (hipótesis nula  $E \leq 1\%$ )

El resultado obtenido no es extraño ya que como se explicó en la sección anterior 36 de los 42 puntos se encuentran por debajo del límite establecido del 1%, por lo cual también se aprecia que el estadístico de prueba es mucho menor que el estadístico obtenido a partir del nivel de significación.

- Rango 2 (Q<9000 SCFD)

En el caso de este rango sólo 4 puntos se encuentran con un error menor al 1%, lo cual es predecible ya que la incertidumbre de la Placa Orificio para este rango es muy alta debido a la poca presión diferencial generada.



33000 SCFD con una Prueba Estadística y se analizaron las causas de este comportamiento.

## CAPÍTULO VI

### EVALUACIÓN ECONÓMICA

#### 6.1 Costos de nueva línea de medición

##### 6.1.1 Costo de ingeniería

Los costos de ingeniería se detallan a continuación en la Tabla 6.1

**Tabla 6.1** Costos detallados de ingeniería para la instalación de caudalímetro másico térmico

Item	Descripción		Cant.	P. Unit.	P. Total
				US \$	US \$
1	Gestión del Proyecto				
	1.1	Estimado de Inversión	1.00	200	200
2	Ingeniería				
	2.1	Ingeniería de Detalle	1	1250.00	1250.00
	2.2	Planos actualizados y As-Built	1	500.00	500.00
Subtotal					1750.00
Contingencias (15%)					262.50
Total					2012.50

El estimado de inversión comprende la selección del caudalímetro, así como los accesorios para el montaje mecánico y eléctrico del mismo. Además comprende la parametrización del caudalímetro. La Ingeniería de Detalle comprende la elaboración de los Protocolos de Pruebas, así como el establecimiento del Procedimiento de Prueba descrito en el Capítulo 5.

### **6.1.2 Costo de Equipo**

En la tabla 6.2 se incluye el costo detallado de todos los materiales utilizados para el montaje mecánico y eléctrico del caudalímetro. Cabe resaltar que tal como indican los respectivos planos, se incluye la instalación de un nuevo tren de medición bridado de 1", así como la alimentación eléctrica desde el Tablero de Control de la Batería OR-11. Se incluyen las respectivas reservas en la caja de paso para la futura instalación de más caudalímetros.

### **6.1.3 Costo de Montaje**

Los costos de montaje que se muestran en la Tabla 6.3 incluyen la mano de obra tanto para el montaje mecánico, eléctrico así como para las pruebas comparativas entre caudalímetros.

**Tabla 6.2** Costos Detallados de Materiales para la Instalación de  
Caudalímetro Másico Térmico

Item	Descripción	Unidad de Medida	Cant.	P. Unit.	P. Total
				US \$	US \$
1	CAJA DE PASO T/"T" GUAL DE 1" MARCA CROUSE HINDS	EA	1	52.00	52.00
2	REDUCCIONES BUSHING DE 2" A 1"	EA	2	1.00	2.00
3	SELLOS CORTAFUEGO DE 1/2	EA	5	14.00	70.00
4	CABLE DE INSTRUMENTACION APANTALLADO 1 PAR X 16AWG + SHIELD - DIXON	MTS	15	1.26	18.90
5	CABLE DE INSTRUMENTACION APANTALLADO 1 PAR X 14AWG + SHIELD - DIXON	MTS	35	2.68	93.80
6	TUBOS DE PVC 1"	EA	6	4.80	28.80
7	COPLES DE 1" GALVANIZADOS	EA	10	1.35	13.50
8	TUBO CONDUIT DE 1"	EA	3	26.95	80.85
9	RIEL UNISTRUD RANURADO	EA	2	42.00	84.00
10	CURVAS DE PVC DE 1"	EA	5	1.20	6.00
11	CABLE VULCANIZADO 3 X 14 AWG	MTS	50	1.65	82.50
12	CINTA AISLANTE 3M SCOTH 33	EA	3	5.33	15.99
13	CINTA VULCANIZANTE 3M SCOTH 23	EA	2	13.59	27.18
14	TERMINAL TIPO FERRUL PARA CABLE 16 AWG	EA	20	0.08	1.60
15	BORNERAS PORTAFUSIBLE CON FUSIBLE DE 2 AMP DE 2.5 AMP	EA	20	6.51	130.20
16	BORNERAS UNIVERSAL DE 2.5 MM	EA	4	1.20	4.80
17	INTERRUPTOR TERMOMAGNETICO DE 2 X 6 AMP REF. A9F74210 MARCA SCHENIDER ELECTRIC	EA	2	35.00	70.00
18	Tubo Acero Inoxidable 314 - Diámetro 1 Pulgada - Sch. 40	MTS	3	2.50	7.50
19	Caudalímetro Másico Térmico ST-75V	EA	1	4960.00	4960.00
Total (\$)					5749.62

**Tabla 6.3** Costos Detallados de Montaje para la Instalación de Caudalímetro  
Másico Térmico

Item	Descripción	Unidad de Medida	Cant.	P. Unit.	P. Total
				US \$	US \$
1	EXCAVACION DE ZANJA DE 0.60 X 0.40 X 50MTS	m3	12	25.00	300.00
2	RELLENO DE ZANJA DE 0.20 X 0.60 X 540 MTS CON CEMENTO	m3	6	65.00	390.00
3	RELLENO DE ZANJA DE 0.40 X 0.60 X 540 MTS	m3	12	12.00	144.00
5	TENDIDO DE TUBERIA DE PVC DE 1"	mts	5	2.00	10.00
6	TENDIDO DE CABLE DE CONTROL DE 2 X 14, 2x12†SHIELD	mts	50	1.45	72.50
7	TENDIDO DE TUBO CONDUIT Y ASCESORIOS	mts	6	14.00	84.00
8	CONEXIONADO DE INTERRUPTORES DE NIVEL Y ASCESORIOS	GBL	1	120.00	120.00
9	PRUEBAS Y PUESTA EN MARCHA	GBL	1	600.00	600.00
10	TRANSPORTE DE PERSONAL Y MATERIALES	DIAS	3	85.00	255.00
Total (\$)					1975.50

## 6.2 Beneficios de Nuevo Sistema

### 6.2.1 Beneficios por la mejora en la medida

Como se expuso en el capítulo 5 la mejora en la medida es de una alta incertidumbre (5 – 20 % span – 20196 SCFD) a menos del 1% (1009,8 SCFD). Este beneficio es muy apreciable en el rango 2 (0 – 9000 SCFD), el cual será utilizado para la estimación económica de los beneficios en la mejora de la medida.

El principal beneficio de una medición con baja incertidumbre son los balances de gas que se realizan en todo el Lote X, ya que como se explicó en el Capítulo II el gas luego de la separación primaria y conteo llega a las estaciones de compresión. En consecuencia se tiene un costo por compresión

de gas. Se realiza un contraste entre la medición en la entrada de la estación de compresión con los medidores instalados en cada línea de prueba.

### **6.2.2 Beneficio por la demanda de mantenimiento**

Debido a la diferencia entre la construcción de los equipos se tiene una mejora importante en los mantenimientos preventivos realizados en el caudalímetro. Actualmente en el Lote X se tiene un total (en OR-11) de seis medidores Placa Orificio para la medición de Gas Asociado, los cuales de acuerdo al programa de Mantenimiento requieren ser inspeccionados dos veces al año para la verificación de la condición de los platos orificios, así como la respectiva verificación de la medición. Cabe resaltar que el tiempo promedio de Mantenimiento de las Placa Orificio son aproximadamente cuatro horas por cada uno.

Con la instalación de estos nuevos dispositivos (caudalímetro másico térmico) se reducirá la intervención a una anualmente. Luego ya con un estudio de Mantenimiento por Estado y Condición sólo atender los caudalímetros una vez cada dos años. El tiempo estimado de mantenimiento y verificación de medición es 1 hora. Esto se debe a que sólo se requiere inspeccionar la sonda y verificar el estado de las tarjetas electrónicas del caudalímetros.

## **6.3 Estimación de Tiempo de Recuperación de la Inversión**

### **6.3.1 Gráfico de Punto de Equilibrio**

Las consideraciones que se tomarán en cuenta son las siguientes:

1<sup>ro</sup> Cantidad de Caudalímetros a instalarse: 32 (Batería OR-11 y otras en el Lote X)

2<sup>do</sup> Debido a que se cambia un pozo de prueba cada 2 días por separador, se considerará que el 50% de los pozos que se miden se encuentran entre 0 a 9000 SCFD. Esto es debido a que de acuerdo a los inventarios de pozos en el Lote X se tiene este porcentaje de pozos con la medición en este rango.

3<sup>ro</sup> Se considerará para todos los fines la tasa de cambio de 2,65 soles/dólar.

4<sup>to</sup> Para la estimación de los beneficios en mejora de la medida se tomará en cuenta los siguientes factores de conversión:

1SCF=2.72013 BTU

1Pie3=1000 BTU

\$2,75=1 MM BTU, dada la tasa de conversión tenemos:

S/7,288=1 MMBTU, este es el costo de Gas Comprimido facturado (obtenido de reporte de PerúPetro, precio de Gas Natural en el año 2012)

5<sup>to</sup> La concesión del Lote X que tiene Petrobras Energía del Perú es hasta el 2024, por lo tanto el análisis tendrá un horizonte de tiempo de 11 años. Los costos de mano de obra de las cuadrillas de instrumentación y gasfiteros serán los que actualmente tiene la empresa con la contratista.

- Estimación de Costos:

De las tablas 6.1, 6.2 y 6.3 tenemos lo siguiente:

**Tabla 6.4** Costos Totales de la Instalación de un Caudalímetro Másico Térmico

Item	Descripción	P. Total
		US \$
1	Costos Ingeniería	2012.5
2	Costo Materiales	5749.62
3	Costo Obras	1975.5
Total		9737.62

El total del Costo de la instalación de un caudalímetro másico térmico es \$9737,62 que al cambio en soles fue S/25 804,33.

- Estimación de Beneficios:

Dado que se considera que el 50% del tiempo se tiene el separador con pozos en el rango de 0 a 9000 SCFD, se muestra a continuación en siguientes tablas los cálculos y consideraciones para la estimación de beneficios obtenidos por mejora en la medida y mejora en mantenimiento respectivamente.

Para la mejora en la medida se consideró que el caudalímetro másico térmico mide el 0.5% de la escala total, aproximadamente 510 SCFD.



**Tabla 6.5** Estimación de Mejora en medida para pozos en Rango de 0 a 9000

## SCFD

<b>Item</b>	<b>Fecha</b>	<b>Hora</b>	<b>Valor PO (SCFD)</b>	<b>Valor Máximo Térmico (SCFD)</b>	<b>Error Span (SCFD)</b>	<b>Mejora en Medición (SCFD)</b>
1	02/05/2012	15:00	200	2600	2400	1890
2	02/05/2012	15:05	7812.7	8620	807.3	297.3
3	02/05/2012	15:10	5120	2356.3	2763.7	2253.7
4	02/05/2012	15:15	5540	9067.3	3527.3	3017.3
5	02/05/2012	15:20	6170	1883.5	4286.5	3776.5
6	02/05/2012	15:25	4650	14877.4	10227.4	9717.4
7	09/05/2012	15:00	1130	17775	16645	16135
8	09/05/2012	15:10	330	21020.1	20690.1	20180.1
9	09/05/2012	15:20	7310	9435.9	2125.9	1615.9
10	09/05/2012	15:25	1102	19132.4	18030.4	17520.4
11	16/05/2012	15:00	6990	15417.5	8427.5	7917.5
12	16/05/2012	15:05	6430	7822.3	1392.3	882.3
13	16/05/2012	15:10	2300	2577.7	277.7	-232.3
14	16/05/2012	15:15	7720	12486.6	4766.6	4256.6
15	16/05/2012	15:20	4630	15941.5	11311.5	10801.5
16	16/05/2012	15:25	8340	9681	1341	831
17	23/05/2012	15:00	5340	2593.5	2746.5	2236.5
18	23/05/2012	15:05	3270	7307.4	4037.4	3527.4
19	23/05/2012	15:10	7080	12357	5277	4767
20	23/05/2012	15:15	7710	9376	1666	1156
21	23/05/2012	15:20	8190	16134.4	7944.4	7434.4
22	23/05/2012	15:25	5500	6251.6	751.6	241.6
23	23/05/2012	15:30	3680	3876.1	196.1	-313.9

El promedio de las mejoras en la medición es 5213.443 SCFD y es el valor que se utilizará para la estimación de la mejora en la medida.

De acuerdo a la cuarta consideración, utilizamos las conversiones para convertir el Volumen a BTU y a Soles respectivamente. Se considera que durante la mitad del año se miden pozos con caudal entre 0 y 9000 SCFD.

**Tabla 6.6** Conversión de Mejora en SCFD a Soles por Año

<b>Mejora en Medida</b>				
<b>SCFD</b>	<b>CFD (Pie Cúbico/Día)</b>	<b>BTU/día</b>	<b>Mejora por día (S/.)</b>	<b>Soles/Año</b>
5213.443	2579.35	2579350	18.797	3430.455

Por lo tanto la mejora en medición por caudalímetro instalado por año es S/.3430,455.

Para la estimación de la medida por mejora en mantenimiento se tendrá en cuenta las horas hombre que se ahorran por caudalímetro en comparación con la placa orificio.

Con la mejora del ahorro de horas de intervención se tiene una mayor disponibilidad de la cuadrilla de instrumentación, lo cual se refleja en un menor número de paradas.

**Tabla 6.7** Estimación de beneficios por año por intervenciones de  
Mantenimiento

<b>Descripción</b>	<b>Valor</b>	<b>Unidad</b>
Costo Cuadrilla por Hora	33.33	dólares/hora
Intervenciones al año (Placa Orificio)	2	
Horas Hombre Anuales (Placa Orificio)	8	horas
Horas Hombre Anuales (Másico Térmico)	2	horas
Mejora en Horas Hombre	6	horas/año
Mejora en Horas Hombre	199.98	dólares/(año-caudalímetro)
Mejora en Horas Hombre	529.947	soles/(año-caudalímetro)

Para estimar la mejora en mantenimiento por este efecto se calculará primero la producción promedio de los compresores en el Lote X, luego con las horas ganadas se estimará la producción de gas comprimido asociado, lo cual se convertirá a soles por año por caudalímetro instalado.

**Tabla 6.8** Inventario de Compresores Lote X

ITEM	UBICACIÓN	MARCA	MODELO	CAPACIDAD (MMSCFD)
1	EPN-30	Waukesha	L-5108 GSI	2.50
2		Ajax	DPC-360	1.20
3		Caterpillar	G-3306 NA	1.40
4		Caterpillar	G-3306 NA	1.40
5		Caterpillar	G-3512 SITA	3.80
6		Caterpillar	G-3406 TA	1.00
7		Caterpillar	G-3306 NA	1.00
8	ETA-29	Caterpillar	G-398	1.00
9		Caterpillar	G-398	1.00
10		Caterpillar	G-398	1.00
11	ETA-27	Caterpillar	G-398	1.00
12		Caterpillar	G-398	1.00
13		Caterpillar	G-3408 TA	1.50
14	ETA-28	Caterpillar	G-398	1.00
15		Waukesha	F-1197 GU	0.40
16		Caterpillar	G-398	.
17		Ajax	DPC-600	1.50
18	ELA-06	Caterpillar	G-398	1.00
19		Ajax	C-42	0.20
20		Caterpillar	G-398	1.00
21		Ajax	DPC-600	1.50
22	ECA-18	Ajax	DPC-360	1.20
23	ECA-20	Caterpillar	G-398	1.00
24	ECA-22	Caterpillar	G-398	1.00
25		Ajax	DPC-360	1.20
26		Caterpillar	G-342	0.50
27	CA-20	Ford	Ford-460	0.39
28		Ford	Ford-460	0.39
29		Ford	Ford-460	0.39
30		Ford	Ford-460	0.39
31	ECE-10	Ford	Ford-460	0.50
32		Ford	Ford-460	0.50
33	EZA-04	Caterpillar	G-3508TA	2.00
34		Caterpillar	G-3408TA	1.50
35	EPN-31	Caterpillar	G-3406TA	1.00
37	ECA-17	Ajax	C-42	0.20
38	EBA-35	Ajax	DPC-2803-LE	1.50
39		Ajax	DPC-2803-LE	1.50
40	ALMACEN	Ford	Ford-460	0.39

El promedio de producción de los 40 compresores es 1077631,58 SCFD, con este dato se construye la siguiente tabla para la mejora en compresión de gas:

**Tabla 6.9** Producción asociada por mayor atención en Mantenimiento Preventivo/Correctivo

Descripción	Valor	Unidad
Producción Promedio Compresores	1077631.58	SCFD
Producción ganada por no parar	738.104	SCFD
Producción ganada por no parar	5378.932	Soles/Año

Sumando los resultados de las tres tablas anteriores se tiene un total de beneficios por mejora de 9339.333492 Soles/(Año-Caudalímetro)

En la figura 6.1 se muestra la gráfica Costo-Beneficio considerando la instalación de treinta y dos caudalímetros en el Lote X. Se aprecia que a partir del tercer año se comienzan a tener beneficios por la mejora en la medición y por la reducción de las intervenciones de Mantenimiento. El tiempo de recuperación de la inversión es 2,763 años (ROI)

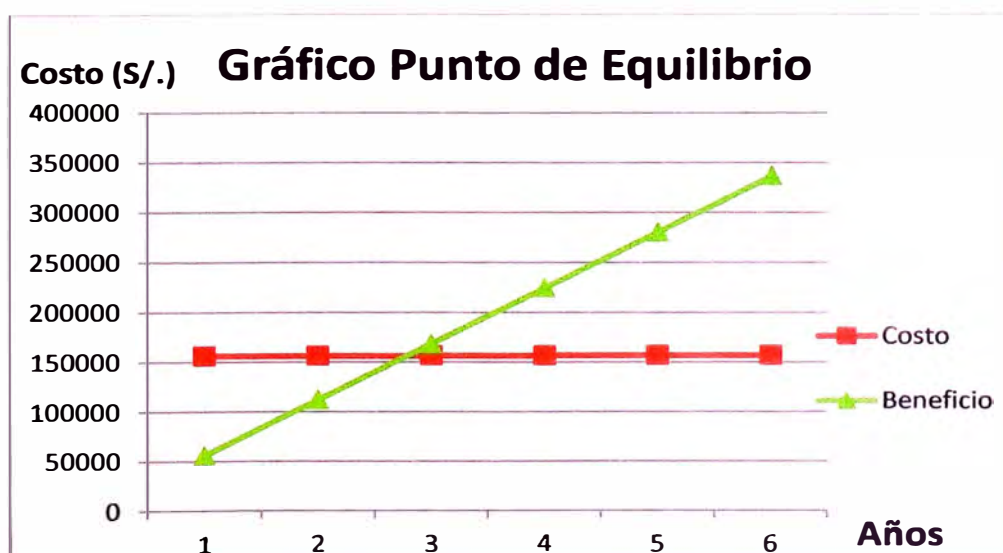

**Fig. 6.1** Gráfico de Punto de Equilibrio para la Instalación de Caudalímetros Másicos Térmicos en la Batería OR-11

En el presente capítulo se verificó que es factible instalar 32 caudalímetros másicos térmico con una Tasa de Retorno de Inversión de 2,76 años. En consecuencia ya en el tercer año se comienza a percibir los beneficios económicos de la instalación del Caudalímetro Másico Térmico.

## **CONCLUSIONES**

Comprobándose que:

1. Se demostró que la precisión del Caudalímetro Másico Térmico se encuentra dentro del 1% del Span de Medición en el rango de 9000 a 33000 SCFD, lo cual es considerado una alta precisión para la medición de gas natural.
2. Se verificó que es factible instalar más caudalímetros másico térmico con una Tasa de Retorno de Inversión de 2,76 años para la instalación de 32. En consecuencia ya en el tercer año se comienza a percibir los beneficios económicos de la instalación del Caudalímetro Másico Térmico.

“Se concluye que es factible implementar un sistema de medición de gas natural mejorado en los Separadores de Prueba del Lote X.”

Lo anterior constituye la tesis que es materia del presente informe.

## BIBLIOGRAFÍA

1. Creús Solé, Antonio, Instrumentación Industrial. México: Alfaomega, 2011
2. Baker, Roger, Flow Measurement Handbook. Estados Unidos: Cambridge University Press, 2005
3. Mokhatab, Saeid, Handbook of Natural Gas Transmission and Processing. Estados Unidos: Elsevier, 2006
4. ISO 5167: 2003, Measurement of fluid flow by means of pressure differential devices inserted in circular cross-section conduits running Part 1: General Principles and Requirements
5. ISO 5167: 2003, Measurement of fluid flow by means of pressure differential devices inserted in circular cross-section conduits running Part 2: Orifice Plates
6. AGA 8: 2003, Compressibility Factors of Natural Gas and Other Related Hydrocarbon Gases
7. Presentación Instalaciones de Superficie - Área de Ingeniería de Producción e Instalaciones – Petrobras Energía del Perú S.A. 2010



## **ANEXOS**

### **ANEXOS**

Anexo 1: Cálculo de Incertidumbre de la densidad.

Anexo 2: Información Técnica actual Sistema de Medición de Caudal

Anexo 3: Información Técnica Caudalímetro Másico Térmico ST-75V

Anexo 4: Protocolos de Verificación de Medición de Caudalímetro Másico Térmico

### **PLANOS**

Plano 1: Plano de Montaje Caudalímetro Másico Térmico SP-1105 OR-11

Plano 2: Diagrama Unifilar Alimentación Caudalímetro Másico Térmico SP-1105

OR-11

## **ANEXOS**

**Anexo 1: Cálculo de Incertidumbre de la densidad.**

## CÁLCULO DE LA INCERTIDUMBRE DE LA DENSIDAD

Para el cálculo de la incertidumbre asociada a la densidad del gas en la Placa Orificio se tendrá en cuenta la ecuación de gases reales:

$$P * V = z * R * T \quad (I)$$

Donde:

P: Presión del Gas (Pa)

V: Volumen del Gas (m<sup>3</sup>)

Z: Factor de Compresibilidad

R: Constante Universal de Gases Ideales ( $8.314 \frac{kPa \cdot m^3}{kmol \cdot K}$ )

T: Temperatura del Gas (K)

Recordando que:

$$\rho = \frac{m}{V} \quad y \quad mol = \frac{m}{\bar{M}}$$

Se reemplaza en la expresión (I) y obtenemos:

$$\rho = \frac{P\bar{M}}{zRT}$$

Se hace un cambio de variable:  $K = \frac{\bar{M}}{R}$

Se tiene la siguiente expresión:

$$\rho = K \frac{P}{zT} \quad (II)$$

De acuerdo a la teoría de errores, obtenemos la siguiente expresión para el error de la función densidad:

$$\delta\rho = \sqrt{\left(\frac{\delta\rho}{\delta P}\Delta P\right)^2 + \left(\frac{\delta\rho}{\delta T}\Delta T\right)^2 + \left(\frac{\delta\rho}{\delta z}\Delta z\right)^2} \quad (\text{III})$$

Desarrollando las derivadas parciales respectivas:

$$\frac{\delta\rho}{\delta P} = \frac{K}{zT}$$

$$\frac{\delta\rho}{\delta T} = -\frac{KP}{zT^2}$$

$$\frac{\delta\rho}{\delta z} = -\frac{KP}{Tz^2}$$

Reemplazando en la expresión III y agrupando los términos, obtenemos:

$$\delta\rho = \sqrt{\left(\frac{K}{zT}\Delta P\right)^2 + \left(\frac{KP}{zT^2}\Delta T\right)^2 + \left(\frac{KP}{Tz^2}\Delta z\right)^2}$$

Dividiendo ambos lados de la ecuación entre  $\rho$ :

$$\frac{\delta\rho}{\rho} = \frac{KP}{zT} \sqrt{\left(\frac{K}{zT}\Delta P\right)^2 + \left(\frac{KP}{zT^2}\Delta T\right)^2 + \left(\frac{KP}{Tz^2}\Delta z\right)^2} \quad (\text{IV})$$

La expresión IV representa la incertidumbre de la densidad como función de la Presión, Temperatura y el Factor de Compresibilidad.

De la ecuación II despejamos z:

$$z = K \frac{P}{\rho T} \quad (\text{V})$$

Para estimar el valor de K, se presenta la tabla I:

**Tabla I** Composición de Gas Natural en Batería OR-11

COMPONENTE		Batería OR-11	
		%Molar	PESO MOL.
<b>Metano</b>	<b>C1</b>	83.239	16.043
<b>Etano</b>	<b>C2</b>	6.326	30.070
<b>Propano</b>	<b>C3</b>	2.877	44.097
<b>Iso-Butano</b>	<b>iC4</b>	1.515	58.123
<b>n-Butano</b>	<b>nC4</b>	1.647	58.123
<b>Iso-Pentano</b>	<b>iC5</b>	1.234	72.150
<b>n-Pentano</b>	<b>nC5</b>	0.809	72.150
<b>Hexano +</b>	<b>C6+</b>	1.644	86.177
<b>Dioxido Carbono</b>	<b>CO2</b>	0.161	44.010
<b>Oxígeno</b>	<b>O2</b>	0.000	31.999
<b>Nitrógeno</b>	<b>N2</b>	0.548	28.013
<b>Total</b>		100.000	21.478

De acuerdo a la Tabla I se tiene que la Masa Molar es 21,478 kg/kmol

Obtenemos con ello el valor de  $K=2,583 \frac{K \text{ kg}}{\text{kPa m}^3}$

Se muestra en la tabla II los valores principales para el cálculo de la incertidumbre de la densidad:

**Tabla II** Valor de variables principales para estimación de incertidumbre de la densidad

<b>Variable</b>	<b>Valor</b>
P	137.895
T	315.222
$\Delta P$	0.001
$\Delta T$	0.008
z	1.282
$\Delta z$	0.001

Reemplazando los valores de la Tabla II en la ecuación IV, obtenemos el siguiente valor:

$$\frac{\delta\rho}{\rho} = 0.00078\%$$

**Anexo 2: Información Técnica actual Sistema de Medición de  
Caudal**



# 8: System Specifications

## General Specifications

### Environmental

Operating Temperature	-40°C to +60°C (-40°F to +140°F) - operating computer -30°C to +65°C (-22°F to +149°F) - non-back-lit alphanumeric displays -10°C to +50°C (14°F to +122°F) - back-lit alphanumeric displays
Storage Temperature	-40°C to +85°C (-40°F to +185°F) - non-back-lit alphanumeric displays -30°C to +65°C (-22°F to +149°F) - back-lit alphanumeric displays
Relative Humidity	Maximum 90% non-condensing (standard display)
Electrical Classification	CSA certification - Intrinsically safe, Class I, Division 1, Groups C & D
Enclosure	CSA certified - Enclosure 3R (Weatherproof) General Purpose

### Physical

Enclosure Material	Fiberglass reinforced plastic (FRP)
Finish	Gray
Size	420 mm (16.5") H x 370 mm (14.6") W x 211 mm (8.3") D
Mounting	Wall mount or a 2" pipe mount (carbon or stainless steel bracket)
Components	Single main circuit board (CPU, memory, communications and I/O circuitry); local LCD display; local keypad (either standard or with optional extended function keypad); battery module w/solar panel or Div 2 DC power supply module (19-28 Vdc).
Rack Mount Option	19" Rack mount configuration. General purpose: 19 - 28 Vdc power supply module. Standard E1A dimensions 3V height.
Weight	Enclosure/Electronics      Net:    13 kg (29 lbs.) DPE+ Cell                      Net:    3.8 kg (8.4 lbs.) each Battery (32Ah):                Net:    11 kg (25 lbs.) Solar Panel: (5 Watt)                      Net:    3 kg (6.5 lbs.) (10 Watt)                     Net:    4 kg (8 lbs.)

	Bracket:	
	(Universal)	Net: 2.3 kg (5 lbs.)
	(Pipe Mt. End Cap)	Net: 1.5 kg (3.2 lbs.)
	(Wall Mount)	Net: 2.3 kg (5 lbs.)
	Shipping	Add 4.5 kg (10 lbs.)
Terminals	Depluggable, 45° 16-28 AWG	

## Computer

CPU	Intel™ 386EX, 32-bit embedded processor, 16 MHz
Coprocessor	Intel™ 387SX math coprocessor (optional)
FLASH	1 Mb standard program memory
RAM	Switch selectable up to 160 Kbytes depending on firmware, static CMOS scratchpad memory
RAM/NVRAM	Up to 768 Kbytes (Total RAM + NVRAM), battery-backed static CMOS
Real Time Clock	Battery backed real-time clock/calendar, 1 second resolution
	Accuracy: ± 1 minute per month @ 25°C (+77°F)
	Stability: ± 3 ppm/°C from -10°C to +60°C (+15°F to +140°F)
	± 5 ppm/°C over full operating temperature
Monitors	Watchdog Timer
	Hardware write protection on NVRAM
NVRAM Battery	Single cell lithium, powers clock and NVRAM
	Provides one year of unpowered backup
	Replaceable in safe area

## Communications

Quantity	4 Ports
Port 1	Accessible through a DB9 or round Fischer 8-pin connector or on the main board with small expansion boards (e.g. Remote Console Serial Port or Comm. Accessory Board). <sup>1</sup>
	Type: RS-232C, Bi-directional
	Signals: Tx, Rx, DSR and Gnd
	Handshake: Software only (XON/XOFF)
	Typical Usage: Console device (IBM PC-compatible or handheld terminal), Gas Chromatograph (GC)

<sup>1</sup> If the optional serial ports (3 and 4) are **not** installed, Port 1 is multiplexed and automatically switches between the console connector (with DSR input) and the shared port. The shared port will accommodate a 3-wire serial RS232 device. The shared terminals for Port 1 are #8 (Tx), #9 (Rx) and #10 (Gnd).

Port 2 (A02)	<p>Located on main board (terminal strip connections 1-7)</p> <p>Type: RS-232C, (optional RS-422, or RS-485)</p> <p>Signals: Rx, Tx, RLSD (DCD), RTS, CTS, DTR, and Gnd</p> <p>Handshake: Hardware or Software</p> <p>Typical Usage: Modem or other serial device (user-selectable), Network port Second console port, or GC</p>
Port 3 (A03)	<p>Located on main board (terminal strip connections 8-13)</p> <p>Type: RS-232C</p> <p>Signals: RX, TX, RTS, CTS, RLSD and GND</p> <p>Handshake: Hardware or Software</p> <p>Typical Usage: Modem or other serial device (user-selectable), Network port Second console port, or GC</p>
Port 4 (A04)	<p>Located on main board (terminal strip connections 14-19)</p> <p>Type: RS-232C (optional RS-422, or RS-485)</p> <p>Signals: RX, TX, RTS, CTS, RLSD and GND</p> <p>Handshake: Hardware or Software</p> <p>Typical Usage: Modem or other serial device (user-selectable), Network port Second console port, or GC</p>
Baud Rate	Selectable from 75, 110, 150, 300, 600, 1200, 2400, 4800, 9600, ( <i>14,400, 19,200 up to 38,400 - limited number of ports</i> )
Parity	Selectable from odd, even, none
Stop Bits	Selectable, 1 or 2
Protection	All inputs and outputs are protected against $\pm 40$ V steady state over-voltage, plus 500 W surge for 1 msec.

## Communications Expansion Boards

(See chapter 3: [Expansion Boards](#) for further expansion board specifications)

**Remote Console Board** (CN2 Terminals) Parallel console port enables the console communications port to be wired to another location. Typically, this is used with a Remote Calibration Unit (RCU).

**Comm. Accessory Board** (CN3 Terminal) Provides the same serial communication terminals as the remote console port, and in addition provides:

DTR Terminals:

Provides +7 Vdc for the operation of a line-powered modem.

Vtx Terminal:

Provides uninterrupted power for accessories, unlike the standard Vtx terminal found on the Scanner main terminal strip, this Vtx terminal is not turned on/off in the power save mode. With battery modules, 15 or 30 Ah, this voltage is maintained at 10 Vdc  $\pm$  1 V.

**Ethernet-Bluetooth Board** (CN10 Terminal) Adds Ethernet and Bluetooth interfaces to the Scanner 1131. Ethernet communications allows users to collect and store Scanner history records to SCM format and upload them at Ethernet speed from anywhere on the Local Area Network. Bluetooth communications provides wireless data transfer up to 100 meters, eliminating the need for serial cable connections.

Operating Temperature:

-40°C to +85°C (-40°F to +185°F)

Hardware:

32-bit NET+ARM high-performance RISC processor (NS7520 @ 55 MHz)

4 MB Flash and 8 MB RAM on-board memory

On-board power supervisor

Network Interface:

Standard: IEEE 802.3

Physical Layer: 10/100Base-T

Data rate: 10/100 Mbps (auto-sensing); maximum 19.2 kbps

Mode: Full or half duplex (auto-sensing)

Connector: RJ-45

802.3af mid-span power pass-through

LEDs on module:

Link integrity

Network activity

## Power Requirements:

3.3VDC @ 250 mA typical (825 mW)

## I/O Expansion

Number of Connectors 2 (Refer to chapter 3: [Expansion Boards](#))

## Display

Type	LCD	4 line x 20, alphanumeric (full ASCII character set)
	back-lit LCD	4 line x 20, alphanumeric, LED back-lit
Viewing Area	Alphanumeric:	70 mm x 21 mm (2.758" x .8274")
Character Format	Alphanumeric:	5 x 8 dots
Character Size	Alphanumeric:	2.95 x 5.55 mm
Operating Temperature		-30°C to +65°C (-22°F to +149°F) - non-back-lit alphanumeric displays -10°C to +50°C (14°F to +122°F) - back-lit alphanumeric displays
Storage Temperature		-40°C to +85°C (-40°F to +185°F) - non-back-lit alphanumeric displays -30°C to +65°C (-22°F to +149°F) - back-lit alphanumeric displays

## Local Keyboard

Keys 8 Keys: *page up*, *page down*, *line up*, *line down*, *details*, *units*, *mode*, and *pause*

Keys allow viewing (but not altering) flow data. Keypad and display, located on the front of the enclosure (or on the door), are externally accessible.

## Keypad (Extended Functions)

Keys 20 keys (refer to the [Extended Function Keypad](#) section)

Keys are suitable for data entry without a terminal. Alpha characters cannot be entered. Local keypad is still functional. The Extended Function Keypad is located on the enclosure door below the local keypad.

Also refer to chapter 4: [Local Display Menu Path \(NFlo & IGas 4.X\)](#) for more details.

## Battery Charger/Power Supply

The 12Vdc battery charger/power supply boards feature a temperature compensated lead acid battery charger circuit that can be powered from a solar panel or an external DC power supply.

### 12 Vdc Charger / Power Supply Board for Div. 1 Areas

When using this board, the Vtx Transmitter Supply switch (SW11) should be set to 10Vdc – see [page 36](#).

Board Part Number 9A-1131-0301C

Board Assembly Number	ASM-3655802	
Area Use	CSA Intrinsically Safe Class 1, Div. 1, as per sheet 3 of 11 (Document 9A-1131-11002) - <b>Drawing 3: Power Supply (Div. 1)</b> . Also certified for Class I, Div. 2.	
Solar Panel	10 Watt (standard) Groups C and D 18 Watt (optional) Group D only	
Battery (standard)	12V/32Ah Nominal rechargeable, sealed, lead acid, c/w temperature compensated, charge controller and voltage regulation (standard). System backup depends on temperature, sample rate and battery capacity.	
Battery Charger	Type:	Temperature compensated two-step voltage controlled charger
	Input Voltage:	13 to 28 Vdc maximum
	Voltage Drop:	2.5 V maximum @500 mA (supply to battery)
	Current Limit:	750 mA nominal
	Charger Float Voltage:	Adjustable to 14.0 V $\pm$ 10% (factory set to 14.0 V @ room temperature)
Scanner RTU Supply Output	Shutdown Battery Voltage	8.5 to 9.5 Vdc
	Restart Battery Voltage	10.7 to 12.1 Vdc
Transmitter Supp. Output (Vtx)	9 - 11 Vdc @ 15 mA	
Environmental	Operating Temperature:	-40°C to +60°C
	Storage Temperature:	-55°C to +80°C
	Relative Humidity:	0-95% non-condensing
Supervisory Signals	Input and battery voltages are reported to the main board for monitoring.	

## 12 Vdc Charger / Power Supply Board for Div. 2 Areas

A modem/radio supply option provides a high power current limited output that can be controlled by the system board. This optional switch allows the computer to control the power supplied to a separate radio/modem so that the average power consumption of the system can be minimized. The radio/modem would be typically powered up for a short period each hour or each day when communication with a host computer is expected. The switch is protected from short circuit and is only available for Div. 2 applications.

**When using this board, the Vtx Transmitter Supply switch (SW11) should be set to 10 Vdc – see page 36.**

Board Part Number	9A-1131-0302C
Board Assembly Number	ASM3655803
Area Use	CSA Class 1, Div. 2, as per sheet 2 of 11 (Document 9A-1131-11022) - <b>Drawing 13: Power Supply (Div. 2 or Zone 2)</b>
Battery (standard)	12 V / 32 Ah Nominal rechargeable, sealed, lead acid, c/w temperature compensated, charge controller and voltage regulation (standard). System backup depends on temperature, sample rate and battery capacity.
	<b>Note:</b> Larger battery requires external charge controller and a larger enclosure.

Solar Panel <sup>2</sup>	10 or 20 watt panel	
Battery Charger	Type:	Temperature compensated two-step voltage controlled charger
	Input Voltage:	13 to 28 Vdc maximum
	Voltage drop:	2.5 V maximum @ 500 mA (supply to battery)
	Current Limit:	750 mA nominal
	Charger Float Voltage:	Adjustable to 14.0 V ±10% (factory set to 14.0V @ room temperature)
Scanner RTU Supply Output	Shutdown Battery	
	Voltage:	8.5 to 9.5 Vdc
	Restart Battery Voltage:	10.7 to 12.1 Vdc
Transmitter Supply	Output Voltage (Vtx):	9 - 11 Vdc @ 15 mA

---

<sup>2</sup> The larger 20-watt solar panel is recommended in areas where weather conditions may diminish the panel's power output. While this panel has an output of about 1.2 A, which exceeds the battery charger's current limit, the extra current output is useful in maintaining a full 750 mA current to the battery charger in adverse conditions (e.g. on cloudy days).

Radio/Modem Supply	Output Voltage:	Short circuit protected battery. Switched output with 0.8 $\Omega$ maximum series resistance.
	Max. Load Current:	2.0 A
	Low Voltage Cutoff:	Software controlled plus backup cutoff at 6.5 V
Environmental	Operating Temperature:	-40°C to +60°C
	Storage Temperature:	-55°C to +80°C
	Relative Humidity:	0-95% non-condensing
Supervisory Signals	Input and battery voltages are reported to the main board for monitoring.	

## 24 Vdc Power Supply for Div. 2 Areas

This power supply board is available to meet the higher peak power requirements for the Scanner 1131.

Depending on your installation configuration and requirements, the Vtx Transmitter Supply switch (SW11) may be set to **10 or 24 Vdc** – see [page 36](#). Also, note the **Transmitter Supply Current Limits** listed below.

Board Part Number	9A-1131-0304C
Board Assembly Number	ASM3655604
Area Use	CSA, Class 1, Div. 2, as per sheet 2 of 11 (Document 9A-1131-11022) - <a href="#">Drawing 13: Power Supply (Div. 2 or Zone 2)</a>
Isolated Input Option	Input Voltage: 24 Vdc (19.2 to 28.8 Vdc) Isolation: 500 Vac for 1 minute
Transmitter Supply	Output: 24.0 V $\pm$ 2.4 V (isolated supply) Current Limit: ~240 mA (Switch SW11 in 24 Vdc mode) ~15 mA (Switch SW11 in 10 Vdc mode) – see <a href="#">page 36</a>
Environmental	Operating Temperature: -40°C to +60°C Storage Temperature: -55°C to +80°C Relative Humidity: 0-95% non-condensing
Supervisory Signals:	Input and battery voltages are reported to the main board for monitoring.



# Electrical Inputs and Outputs Specifications

## Analog Inputs

Number of Channels	Optional hardware: 1) Maximum Six 1 – 5 V, single-ended 2) Maximum Six 1 – 5 V or 4 – 20 mA, single-ended or differential, switch selectable 3) Maximum Twelve 4 – 20 mA, single-ended
Transmitter Options	1 - 5 Vdc 4 - 20 mA
Accuracy	$\pm 0.030\%$ of span max. error at +25°C (1 - 5 V) $\pm 0.045\%$ of span max. error at +25°C (4 - 20 mA)
Average Temperature Effect	$\pm 0.0025\%$ of span/°C max. at +25°C (1 - 5 V) $\pm 0.0030\%$ of span/°C max. at +25°C (4 - 20 mA)
Hysteresis	Not measurable
Impedance	> 100K $\Omega$ (1 - 5 V input), ~250 K $\Omega$ (4 - 20 mA)
Linearity	$\pm 0.003\%$ of full scale
A/D Resolution	16-Bit
Temperature Effect	Less than $\pm 0.25\%$ of full-scale change per 100°C (180°F), including shunt resistors and all component errors, excluding transmitter / transducer error.
Filtering	Noise Rejection greater than 55 dB @ 60 Hz
Throughput	Up to 5 conversions / second
Under/Over Range	-25%, +5% of span (nominal)
Protection	Steady state: $\pm 20$ V over-voltage Surge: 500 W for 1 msec.
Calibration	Autocalibration
Typical Usage	Differential pressure, pressure, temperature, specific gravity, heating value (mass), heating value (volume), %CO <sub>2</sub> , %N <sub>2</sub> , and % C1.
Allocation	User-selectable

## Analog Outputs

Quantity	Two
Isolation	Optically isolated to 500 VAC, externally powered
Type	Switch selectable as wither 1 - 5 V or 4 - 20 mA
Accuracy	±0.1% of FS max. Error at 25°C (after factory calibration)
Temperature Effect	±1% of FS max. Error over temperature
Minimum Operating Voltage	9.5 Vdc (4 - 20 mA), 12.5 Vdc (1 - 5 V)
Maximum Voltage	±40 Vdc
Minimum Load (1 - 5 V Mode)	100 KΩ
D/A Resolution	12 bits
Calibration	Zero and full scale software calibration
Settling Time	< 100 msec. to 0.1% of full-scale for a 10% step change
Function	User assignable (flow rate, temperature, etc.)

## Analog to Digital System

Resolution	16 bits
Linearity error	±0.015% typical
Throughput	All inputs converted in less than 0.1 seconds (high power mode only)

## RTD Inputs

Quantity	Two (Standard)
Type	100 Ω 2 or 3-Wire, 100 Ω, platinum, 0.003850 or 0.003902 Ω/Ω/°C curves. Lead length compensation on 3-wire RTD's.
Range (Default)	-45°C to +120°C (-50°F to +250°F)
(User-entered)	up to +210°C (410°F), if lead compensation is less than 1 Ω
Accuracy	± 0.20°C at 25°C ambient including RTD linearization
Temperature Effect	± 0.0065°C measurement error / °C ambient change
Protection	Steady state: ± 40 V over-voltage Surge: 500 W for 1 msec
Allocation	Temperature only
Optional	RTD sensors in terminal housing or with armored wire 10', 20', 30' length, 10" probe with 1/2" NPT weather-resistant strain relief process connection.

## Status Inputs, Status and Pulse Outputs

Quantity	6 assignable/selectable status inputs, status outputs, or pulse outputs
Function	User assignable for signaling alarms, controlling valves, and provides an interface to counters
Input Type	Voltage input or Contact Closure
Maximum Voltage	±40 Vdc
Status Input Threshold	The following values are the guaranteed limits that the input will be detected as having changed state. For example, with a 2 volt selection, the input will be detected as false (off) when the input is less than 0.5 V and on when it is more than 3.5 V. In typical operation, the trip transition points are within 0.5 volts of the nominal threshold.

<b>Nominal Threshold</b>	<b>Maximum Low Level Signal (Impedance)</b>	<b>Minimum High Level Signal (Impedance)</b>
2.0 V	0.5 V	3.5 V
7.0 V	5.0 V	9.0 V
10.0 V	8.0 V	12.0 V
Contact Closure	2 k $\Omega$	200 $\Omega$

Output Type	MOSFET, open drain
Output Surge Protection	300 W for 1 msec
Status/Pulse Output	Max. 100 mA on-state current Max. 0.5 $\Omega$ on-state resistance Max. 40 Vdc off-state voltage
Maximum Pulse Count Rate	16 Hz, 50% duty cycle

## Pulse Inputs

Number of Channels	2 maximum
Signal Type	Switch selectable
Typical Usage	Volume, mass, and energy accumulation (from frequency pulse output device).
Allocation	User-selectable
Specifications:	

<b>Signal Type</b>	<b>Maximum Low Level Signal</b>	<b>Minimum High Level Signal</b>	<b>Frequency Range</b>	<b>Input Impedance</b>	<b>Power Supplied by 1131</b>
2-wire Preamp Low Threshold (page 44)	1.6 mA	2.4 mA	0-8 kHz	620 $\Omega$	Vtx
2-Wire Preamp High Threshold (page 44)	7.3 mA	12.1 mA	0-8 kHz	620 $\Omega$	Vtx
3-Wire Preamp Low Threshold (page 45)	1.0 V	1.5 V	0-10 kHz	>10 k $\Omega$	Vtx
3-Wire Preamp High Threshold (page 45)	4.5 V	7.5 V	0-10 kHz	>10 k $\Omega$	Vtx
Magnetic Pickup Coil (page 46)	<u>Minimum Signal Levels</u> 20 mV p-p @ 20 Hz 20 mV p-p @ 100 Hz 200 mV p-p @ 1000 Hz 400 mV p-p @ 2000 Hz 1000 mV p-p @ 5000 Hz		10 k $\Omega$ @ 1 kHz		
Proximity Sensor (page 46)	1 mA	3 mA	0-5 kHz	N/A	
Contact Closure (page 47)	2 k $\Omega$	200 k $\Omega$	0-10 Hz	N/A	8 Vdc
Open Collector (page 47)	Off-state Leakage 50 $\mu$ A	On-state Current 75 $\mu$ A	Frequency Run 0-5 kHz		Off-state Voltage +8 Vdc

## DPE+ Multi-Variable Transducer

<b>Differential Pressure Accuracy</b>	Stability: Long-term drift is less than $\pm 0.05\%$ of upper range limit (URL) per year over a 5-year period <b>Accuracy (30 In. H2O)</b> $\pm 0.10\%$ for spans $\geq 10\%$ of the sensor URL $\pm(0.010)$ (URL+SPAN) for spans $< 10\%$ of the sensor URL <b>Accuracy (200 to 840 In. H2O)</b> $\pm 0.05\%$ for spans $\geq 10\%$ of the sensor URL $\pm(0.005)$ (URL+SPAN) for spans $< 10\%$ of the sensor URL				
<b>Effect on Differential Pressure for a 100-psi Change in Static Pressure</b>	<b>SP/SWP (PSIA)</b>	<b>DP (IN H2O)</b>	<b>Max. Overrange Pressure (PSIA)</b>	<b>Zero Shift</b>	<b>Span Shift</b>
	100	30	150	$\pm 0.05\%$ of URL	$\pm 0.01\%$ of reading
	300	200	450	$\pm 0.007\%$ of URL	$\pm 0.01\%$ of reading
	300	840		$\pm 0.002\%$ of URL	$\pm 0.01\%$ of reading
	500	200	750	$\pm 0.010\%$ of URL	$\pm 0.01\%$ of reading
	1500	200	2250	$\pm 0.010\%$ of URL	$\pm 0.01\%$ of reading
	1500	300		$\pm 0.004\%$ of URL	$\pm 0.01\%$ of reading
	1500	400		$\pm 0.004\%$ of URL	$\pm 0.01\%$ of reading
	1500	840		$\pm 0.004\%$ of URL	$\pm 0.01\%$ of reading
	3000	200	4500	$\pm 0.010\%$ of URL	$\pm 0.01\%$ of reading
	300	300		$\pm 0.004\%$ of URL	$\pm 0.01\%$ of reading
	3000	400		$\pm 0.004\%$ of URL	$\pm 0.01\%$ of reading
	3000	840		$\pm 0.004\%$ of URL	$\pm 0.01\%$ of reading
	5300	200	7420	$\pm 0.010\%$ of URL	$\pm 0.01\%$ of reading
	5300	300		$\pm 0.004\%$ of URL	$\pm 0.01\%$ of reading
	5300	400		$\pm 0.004\%$ of URL	$\pm 0.01\%$ of reading
	5300	840		$\pm 0.004\%$ of URL	$\pm 0.01\%$ of reading
<b>Static Pressure Accuracy</b>	<b>Accuracy (500 psia)</b> $\pm 0.05\%$ for spans $\geq 5\%$ of the sensor URL $\pm(0.0025)$ (URL+SPAN) for spans $< 5\%$ of the sensor URL <b>Accuracy (300, 1500, 3000 and 5300 psia)</b> $\pm 0.05\%$ for spans $\geq 10\%$ of the sensor URL $\pm(0.0025)$ (URL+SPAN) for spans $< 10\%$ of the sensor URL				
<b>Temperature Performance</b>	$\pm 0.25\%$ of full scale over full operating temperature range				

## DPE+ Pressure Limits and Bolt Specifications

SP/SWP (PSIA)	DP (IN H2O)	Max. Overrange Pressure (PSIA)	Standard Bolts	Limited NACE Bolts (not for offshore) <sup>a</sup>	Full NACE Bolts
100	30	150	B7 or 316 SS (with SS vent plug)	B7M (no vent plug)	B7M (with Hastelloy vent plug)
300	200	450	B7 or 316 SS (with SS vent plug)	B7M (no vent plug)	B7M (with Hastelloy vent plug)
300	840				
500	200	750	B7 or 316 SS (with SS vent plug)	B7M (no vent plug)	B7M (with Hastelloy vent plug)
1500	200	2250	B7 or 316 SS (with SS vent plug)	B7M (no vent plug)	B7M (with Hastelloy vent plug)
1500	300				
1500	400				
1500	840				
3000	200	4500	B7 or 17-4 SS (with SS vent plug)	Inconel (no vent plug)	Inconel (with Hastelloy vent plug)
3000	300				
3000	400				
3000	840				
5300	200	7420	B7 <sup>b</sup> (with SS vent plug)	Inconel <sup>b</sup> (no vent plug)	Inconel <sup>b</sup> (with Hastelloy vent plug)
5300	300				
5300	400				
5300	840				

<sup>a</sup> A regular stainless steel plug is substituted for the vent plug in limited NACE units.

<sup>b</sup> Not available with Canadian CRN or ANSI 12.27 Single Seal certification.

# Order Code

Shaded selections indicate stocked items													
1131 Code Example: 1131													
	C	02	IM	00	11	M	10	26	33	33	83R	2C	
<b>1 ENCLOSURE</b>													
Field Mount - (Nema 4 Fibreglass Reinforced Plastic) External Fischer OEM (Div II Non Incendive)	C												
Rack Mount (Div 2, non-incendive)	G												
Field Mount (Nema 4 Carbon Steel)	R												
	S												
<b>2 CERTIFICATION</b>													
None		00											
CSA ordinary locations		01											
CSA Intrinsically Safe, Class I, Div 1, Groups C & D, Typ4 [1131L]		02											
CSA non-incendive, Class I, Div 2, Groups A,B,C & D Typ4 [1131L]		C2											
CSA IS, Class I, Div 1, Groups C & D, Typ3R [1131C,1131S]		32											
CSA NI, Class I, Div 2, Groups A,B,C & D Typ3R		06											
CSA ordinary locations - MC Lock (1)		11											
CSA IS, Class I, Div 1, Grps C & D - MC Lock (1)		33											
CSA NI, Class I, Div 2, Groups A,B,C & D - MC Lock (1)		16											
(1) includes Configuration Lock Seal for Measurement Canada (MC)													
<b>3 TRANSDUCER</b>													
No Transducer		00											
Remote Mount DPE Transducer (Specify as separate line item) <sup>1</sup>		RM											
Integral Mounted DPE Transducer (Specify as a separate line item) <sup>1</sup>		IM											
Integral Mounted Pressure Transmitter, 100PSIG (1)		P1											
Integral Mounted Pressure Transmitter, 200PSIG (1)		P2											
Integral Mounted Pressure Transmitter, 300PSIG (1)		P3											
Integral Mounted Pressure Transmitter, 500PSIG (1)		P5											
Integral Mounted Pressure Transmitter, 1000PSIG (1)		P6											
Integral Mounted Pressure Transmitter, 1500PSI (sealed gauge) (1)		P7											
Integral Mounted Pressure Transmitter, 3000PSI (sealed gauge) (1)		P8											
Integral Mounted Pressure Transmitter, 5000PSI (sealed gauge) (1)		P9											
<b>NOTE: 3a. Option codes IM or P1-P9 are not available for the 1131G or R</b>													
<b><sup>1</sup> consult factory for availability</b>													
<b>4 TRANSDUCER2</b>													
No Transducer		00											
Remote Mount DPE Transducer (Specify as separate line item)		RM											
Integral Mounted DPE+ Transducer (Specify as a separate line item)		IM											
Integral Mounted Pressure Transmitter, 100PSIG (1)		P1											
Integral Mounted Pressure Transmitter, 200PSIG (1)		P2											
Integral Mounted Pressure Transmitter, 300PSIG (1)		P3											
Integral Mounted Pressure Transmitter, 500PSIG (1)		P5											
Integral Mounted Pressure Transmitter, 1000PSIG (1)		P6											
Integral Mounted Pressure Transmitter, 1500PSI (sealed gauge) (1)		P7											
Integral Mounted Pressure Transmitter, 3000PSI (sealed gauge) (1)		P8											
Integral Mounted Pressure Transmitter, 5000PSI (sealed gauge) (1)		P9											
<b>NOTE: 4a. Option codes IM or P1-P9 are not available for the 1131G or R</b>													

<p><b>5 POWER SUPPLY</b>                  Div1 or Div2, 12-28Vdc /6V Charge control [1131C, 1131S]                  Div2, 12-28Vdc /12V Charge control [1131C, 1131S]                  Div 2, 12-28 Vdc (applicable to all enclosure models)  <b>NOTE:</b>                  5a. All charge controlled power supplies are non-isolated                  5b. Options 11 and 12 are available only with the Field enclosures (Code S or C)</p>	<p>11 12 24</p>																																			
<p><b>6 BATTERY</b>                  None                  12 VDC, 17 Ah (requires Power Supply '11' or '12')                  12 VDC, 32 Ah (requires Power Supply '11' or '12')</p>	<p>X K M</p>																																			
<p><b>7 SOLAR PANEL</b></p> <table border="1" data-bbox="150 584 922 837"> <thead> <tr> <th>Watts</th> <th>Bracket</th> <th>Cable</th> <th>Approval</th> </tr> </thead> <tbody> <tr> <td>None</td> <td>None</td> <td>None</td> <td>n/a</td> </tr> <tr> <td>10</td> <td>Adj.</td> <td>10'</td> <td>Div 1</td> </tr> <tr> <td>20</td> <td>Adj.</td> <td>10'</td> <td>Div2</td> </tr> <tr> <td>30</td> <td>Adj.</td> <td>10'</td> <td>Div 2</td> </tr> <tr> <td>50</td> <td>Vertical</td> <td>None</td> <td>Div 2</td> </tr> <tr> <td>80</td> <td>Vertical</td> <td>None</td> <td>Div 2</td> </tr> </tbody> </table> <p><b>NOTES:</b> 7a. All brackets are for 2" pipe</p>	Watts	Bracket	Cable	Approval	None	None	None	n/a	10	Adj.	10'	Div 1	20	Adj.	10'	Div2	30	Adj.	10'	Div 2	50	Vertical	None	Div 2	80	Vertical	None	Div 2	<p>00 10 20 30 50 80</p>							
Watts	Bracket	Cable	Approval																																	
None	None	None	n/a																																	
10	Adj.	10'	Div 1																																	
20	Adj.	10'	Div2																																	
30	Adj.	10'	Div 2																																	
50	Vertical	None	Div 2																																	
80	Vertical	None	Div 2																																	
<p><b>8 MAIN BOARD (INPUT OPTIONS)</b></p> <table border="1" data-bbox="102 898 922 1084"> <thead> <tr> <th>Analog Inputs</th> <th>DPE / RTD Inputs</th> <th>Freq. In / Analog out</th> <th>Serial 232/485</th> <th>Copro-processor</th> </tr> </thead> <tbody> <tr> <td>[6] 1-5V or 4-20 mA</td> <td>2/2</td> <td>2/2</td> <td>2/2</td> <td>N</td> </tr> <tr> <td>Single or Differential</td> <td>2/2</td> <td>2/2</td> <td>2/2</td> <td>Y</td> </tr> <tr> <td>[12] 1-5V Single Ended</td> <td>2/2</td> <td>2/2</td> <td>2/2</td> <td>Y</td> </tr> <tr> <td>[12] 4-20mA Single Ende</td> <td>2/2</td> <td>2/2</td> <td>2/2</td> <td>Y</td> </tr> </tbody> </table> <p><b>NOTE:</b> 8a. Main board also includes six digital (status) inputs/outputs and 768K memory                  8b. The single ended input configuration 12 is convertible to 4-20mA inputs with the addition of an auxiliary board, included with I/O option 27                  8c. RS-485 ports are switch selectable to RS-232</p>	Analog Inputs	DPE / RTD Inputs	Freq. In / Analog out	Serial 232/485	Copro-processor	[6] 1-5V or 4-20 mA	2/2	2/2	2/2	N	Single or Differential	2/2	2/2	2/2	Y	[12] 1-5V Single Ended	2/2	2/2	2/2	Y	[12] 4-20mA Single Ende	2/2	2/2	2/2	Y	<p>16 17 26 27</p>										
Analog Inputs	DPE / RTD Inputs	Freq. In / Analog out	Serial 232/485	Copro-processor																																
[6] 1-5V or 4-20 mA	2/2	2/2	2/2	N																																
Single or Differential	2/2	2/2	2/2	Y																																
[12] 1-5V Single Ended	2/2	2/2	2/2	Y																																
[12] 4-20mA Single Ende	2/2	2/2	2/2	Y																																
<p><b>9 DISPLAY AND KEYPAD (4 line x 20 character LCD)</b>                  Standard Display, Standard keypad                  Backlit Display, Standard Keypad                  Standard Display, Extended Keypad                  Backlit Display, Extended Keypad</p>	<p>01 B1 11 12</p>																																			



1131 Code Example: 1131		C	02	IM	00	11	M	10	26	33	33	83R	2C	R	00	S
<b>10 EXPANSION BOARD 1</b>																
None										00						
Remote Console Serial Port (ONLY in 1st slot or stacked on another expansion board)										01						
Comm's Accessory Board (ONLY in 1st slot or stacked on another expansion board)										02						
<b>AS01</b>		Analog Outs		Status/Pulse Outs												
Fits either expansion slot		1	1								11					
		3	3								33					
<b>CD01</b>		Comm	Digital	Config												
Fits either expansion slot		Port	I/O	Lock Switch												
		0	4	No												
<b>DI01</b>		Pulse Input- Turbine / PD Meters		Densitometer												
Fits either expansion slot		Standard	Phase Discrimination	Input												
		2	-	-												
		5	-	-												
		-	5	-												
EB02: Ethernet only accessory board (Expansion slot 1 only)										E0						
EB02: Ethernet and Bluetooth accessory board (Expansion slot 1 only)										EB						
NOTE: 7a. For other options please consult factory																
<b>11 EXPANSION BOARD 2</b>																
Use the same order codes as previous field 10 (EXPANSION BOARD 1) above.																
Except EB02 Board, which can not be used in expansion slot 2																
<b>12 PROGRAM</b>		ScanCom	Modbus	BSAP	PLC											
NGas 2 ('85 AGA Gas Calcs)		18R	19R	-												
NGas 3 ('92 AGA Gas Calcs)		38R	39R	L3R												
NGas 4 ('92 AGA Gas Calcs)		note 12a	33R	-												
IGas (ISO Gas Calcs)		note 12a	59R	-												
OPSat (Gas/Oil- Well Testing)		N/A	N/A	-												
NFlo 3 (Gas/Liquids- Hourly Data)		88R	89R	-												
NFlo 4 (Gas/Liquids- Hourly Data)		note 12a	83R	L4R	P4R											
<b>NOTES:</b>																
12a. Please use applicable Modbus program code, since all "4" series firmware versions are provided with ScanCom and Modbus communication protocols																
12b. For other available programs please consult Barton document 1100-1002B																
12c. Scan PLC (IEC61131 programming module) only available with NFio 4 firmware, ScanCom / Modbus Protocol																
<b>13 MOUNTING</b>																
None													00			
2" Pipe Mount Universal (CS)													2C			
2" Pipe Mount Universal (SS)													2S			
Wall Mount Bracket													WL			
2" Pipe Mount Universal (CS)													2C			
2" Pipe Mount Universal (SS)													2S			
Wall Mount Bracket													WL			
Sliding Rail Kit for 19" Rack Mount Enclosure													10			
<b>14 RTD (Armored 3 wire 100 Ohm Platinum)</b>																
None														A		
10 foot														R		
30 foot														S		
two 10 foot RTD Probes														T		
two 30 foot RTD probes														U		
NOTE: 14a. For non-standard lengths, please consult factory																

1131 Code Example: 1131	C	02	IM	00	11	M	10	26	33	33	83R	2C	R	00	S																																																																																																												
<p><b>15 NOTE: THIS FIELD [15] IS ONLY APPLICABLE TO MODELS 1131C &amp; 1131S FOR ALL OTHER ENCLOSURE STYLES PLEASE SELECT CODE 00</b></p> <p><b>COMMUNICATIONS INTERFACE</b></p> <table border="1" style="width:100%; border-collapse: collapse;"> <thead> <tr> <th colspan="4">Order codes in this table are used to specify a "DCE Ready" Scanner only</th> </tr> <tr> <th colspan="2">Comm Device to Serial Port</th> <th colspan="2">Comm Device to Antenna</th> </tr> </thead> <tbody> <tr><td>None</td><td>0</td><td>None</td><td>0</td></tr> <tr><td>None</td><td>0</td><td>Type N</td><td>N</td></tr> <tr><td>None</td><td>0</td><td>TNC</td><td>T</td></tr> <tr><td>None</td><td>0</td><td>SMA</td><td>S</td></tr> <tr><td>None</td><td>0</td><td>UHF</td><td>U</td></tr> <tr><td>DB25M Connector</td><td>5</td><td>None</td><td>0</td></tr> <tr><td>DB25M Connector</td><td>5</td><td>Type N</td><td>N</td></tr> <tr><td>DB25M Connector</td><td>5</td><td>TNC</td><td>T</td></tr> <tr><td>DB25M Connector</td><td>5</td><td>SMA</td><td>S</td></tr> <tr><td>DB25M Connector</td><td>5</td><td>UHF</td><td>U</td></tr> <tr><td>DB9M Connector</td><td>9</td><td>None</td><td>0</td></tr> <tr><td>DB9M Connector</td><td>9</td><td>Type N</td><td>N</td></tr> <tr><td>DB9M Connector</td><td>9</td><td>TNC</td><td>T</td></tr> <tr><td>DB9M Connector</td><td>9</td><td>SMA</td><td>S</td></tr> <tr><td>DB9M Connector</td><td>9</td><td>UHF</td><td>U</td></tr> <tr><td>Flying Leads</td><td>L</td><td>None</td><td>0</td></tr> <tr><td>Flying Leads</td><td>L</td><td>Type N</td><td>N</td></tr> <tr><td>Flying Leads</td><td>L</td><td>TNC</td><td>T</td></tr> <tr><td>Flying Leads</td><td>L</td><td>SMA</td><td>S</td></tr> <tr><td>Flying Leads</td><td>L</td><td>UHF</td><td>U</td></tr> </tbody> </table> <p>Special, specify as a separate line item</p> <p><b>DCE DEVICE</b> Consult Factory</p> <p><b>NOTES:</b> 14a. Includes pre-wired DCE communication cable, lightning surge protector, and internal co-ax service loop. For non-standard antenna / cabling options, please consult factory. 14b. For communication interfaces not listed, please consult factory. 14c. Please see list of standard options for antenna and external co-ax and specify as a separate option.</p>															Order codes in this table are used to specify a "DCE Ready" Scanner only				Comm Device to Serial Port		Comm Device to Antenna		None	0	None	0	None	0	Type N	N	None	0	TNC	T	None	0	SMA	S	None	0	UHF	U	DB25M Connector	5	None	0	DB25M Connector	5	Type N	N	DB25M Connector	5	TNC	T	DB25M Connector	5	SMA	S	DB25M Connector	5	UHF	U	DB9M Connector	9	None	0	DB9M Connector	9	Type N	N	DB9M Connector	9	TNC	T	DB9M Connector	9	SMA	S	DB9M Connector	9	UHF	U	Flying Leads	L	None	0	Flying Leads	L	Type N	N	Flying Leads	L	TNC	T	Flying Leads	L	SMA	S	Flying Leads	L	UHF	U	00	0N	0T	0S	0U	50	5N	5T	5S	5U	90	9N	9T	9S	9U	L0	LN	LT	LS	LU	SP
Order codes in this table are used to specify a "DCE Ready" Scanner only																																																																																																																											
Comm Device to Serial Port		Comm Device to Antenna																																																																																																																									
None	0	None	0																																																																																																																								
None	0	Type N	N																																																																																																																								
None	0	TNC	T																																																																																																																								
None	0	SMA	S																																																																																																																								
None	0	UHF	U																																																																																																																								
DB25M Connector	5	None	0																																																																																																																								
DB25M Connector	5	Type N	N																																																																																																																								
DB25M Connector	5	TNC	T																																																																																																																								
DB25M Connector	5	SMA	S																																																																																																																								
DB25M Connector	5	UHF	U																																																																																																																								
DB9M Connector	9	None	0																																																																																																																								
DB9M Connector	9	Type N	N																																																																																																																								
DB9M Connector	9	TNC	T																																																																																																																								
DB9M Connector	9	SMA	S																																																																																																																								
DB9M Connector	9	UHF	U																																																																																																																								
Flying Leads	L	None	0																																																																																																																								
Flying Leads	L	Type N	N																																																																																																																								
Flying Leads	L	TNC	T																																																																																																																								
Flying Leads	L	SMA	S																																																																																																																								
Flying Leads	L	UHF	U																																																																																																																								
<p><b>15 SOFTWARE and DOCUMENTATION</b></p> <p>None</p> <p>ScanWin Lite Software and Maintenance Manuals</p>															X	S																																																																																																											

# Outline Dimensions

## Rack Mount

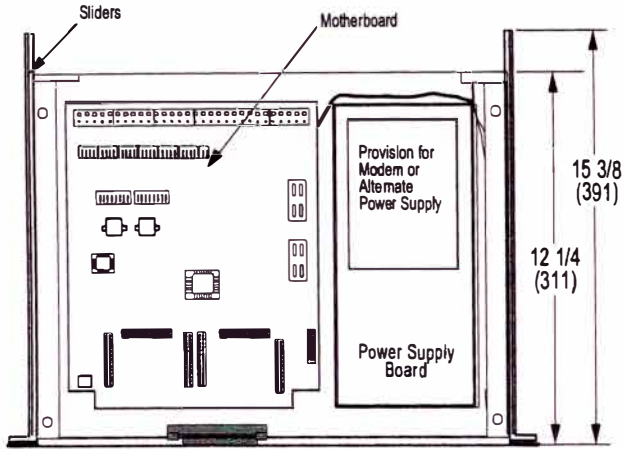

Top View

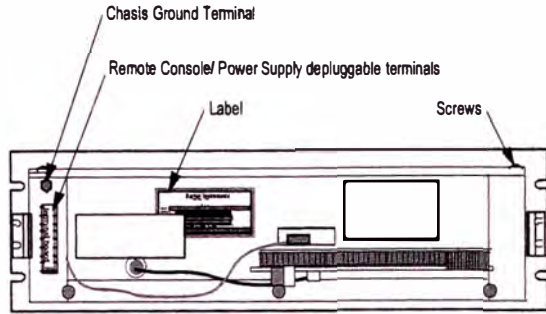

Back View

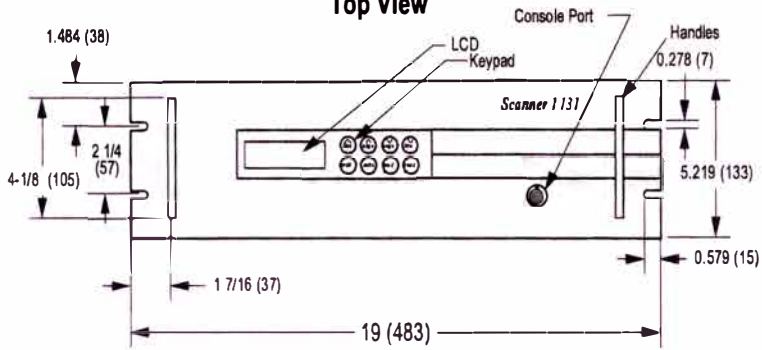

Front View

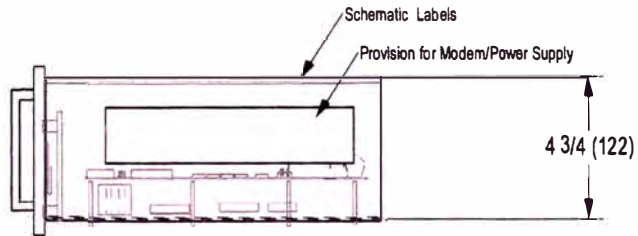

Side View

**Note:** All dimensions are shown in inches (millimeters). Tolerance  $\pm 1/32"$  (1 mm), unless otherwise stated. Top view is shown with the lid removed.

## Scanner 1131C (Front View with Single DPE)

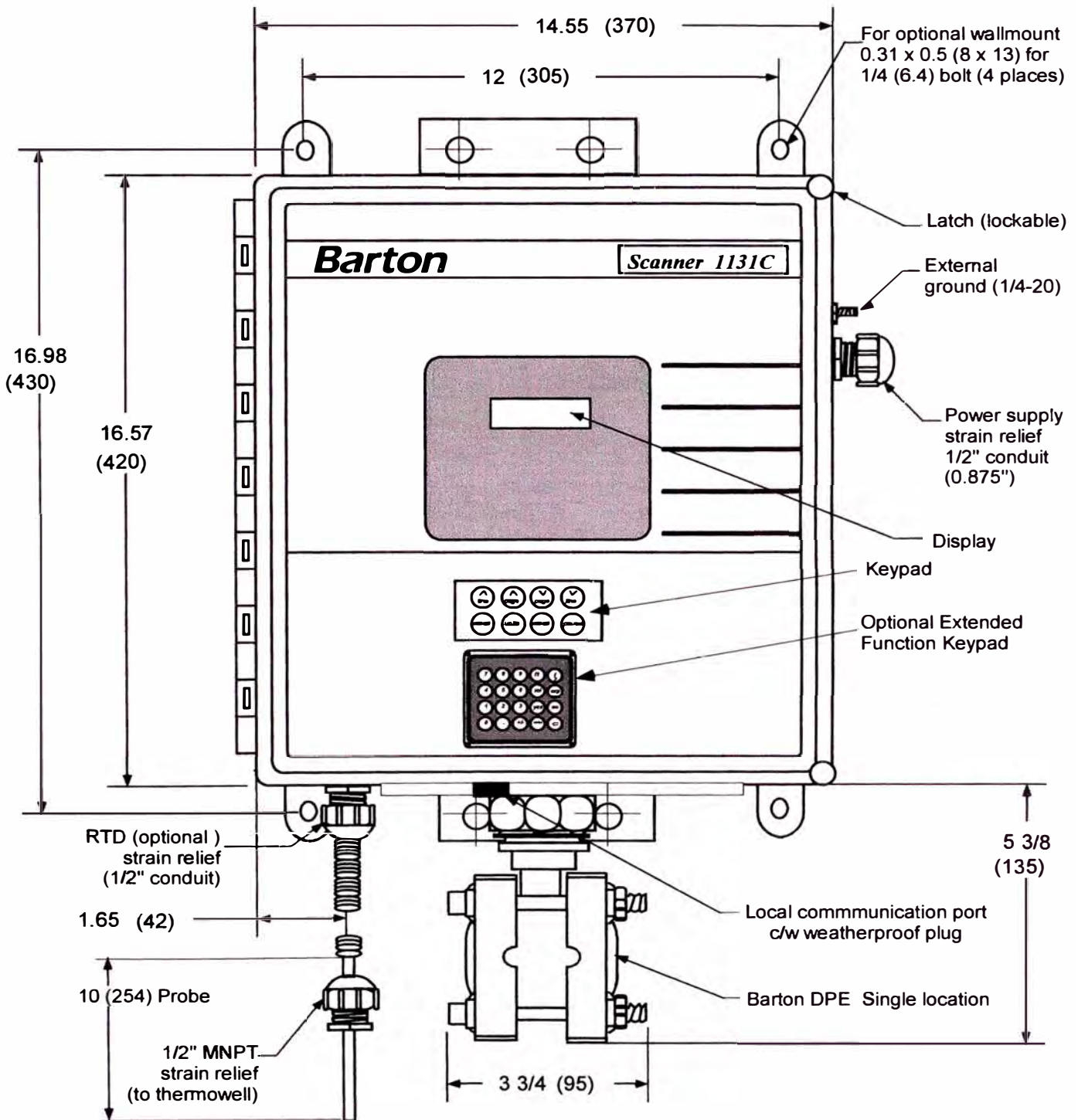

- Notes: 1. All dimensions in inches. (Soft metric conversion) Tolerances:  $\pm 1/8"$  (3.2mm)  
 2. Available mounting options: 2" U-bolt mount and wall mount

## Scanner 1131C (Front View with Two DPE's)

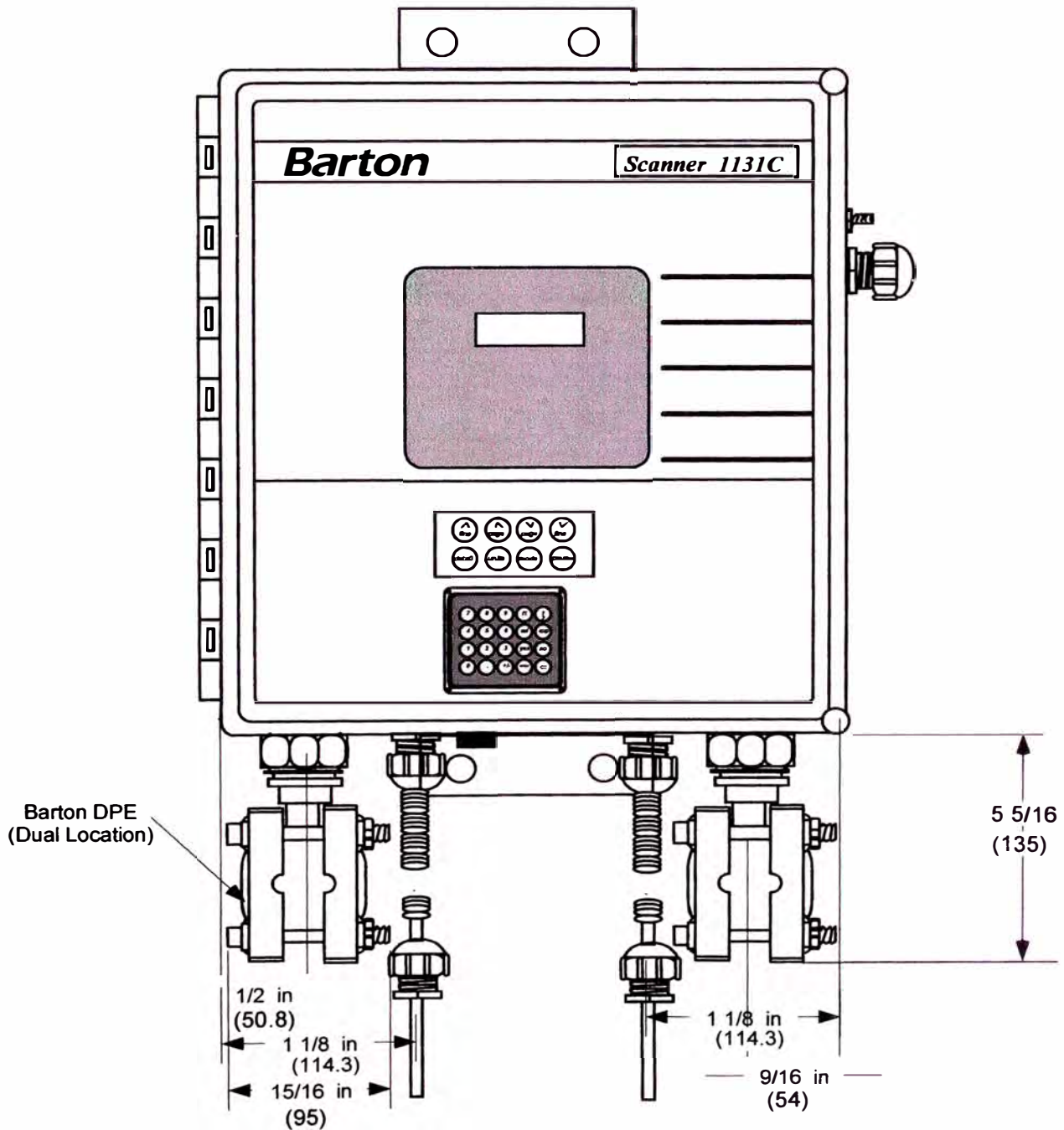

2. Dual DPE Locations shown.

Notes: 1. All dimensions in inches. (Soft metric conversion) Tolerances:  $\pm 1/8"$  (3.2mm)

## Scanner 1131C (Side Views with Universal Mount)

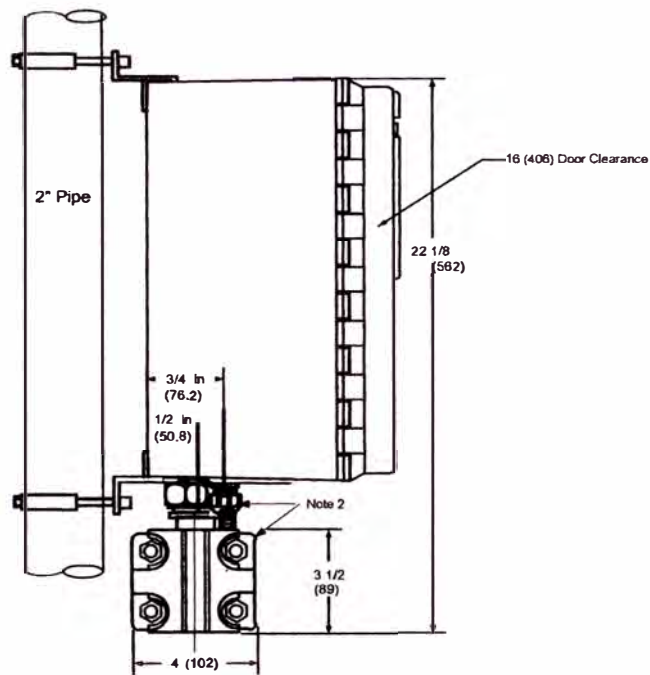

2. Dual Location for RTD and DPE shown. For Single location DPE is 2.25 (57.2) and RTD 2 (50.8)  
 Notes: 1. All dimensions in inches fraction  $\pm 1/32"$ , 0.XX  $\pm 0.01"$ , 0.XXX  $\pm 0.005"$

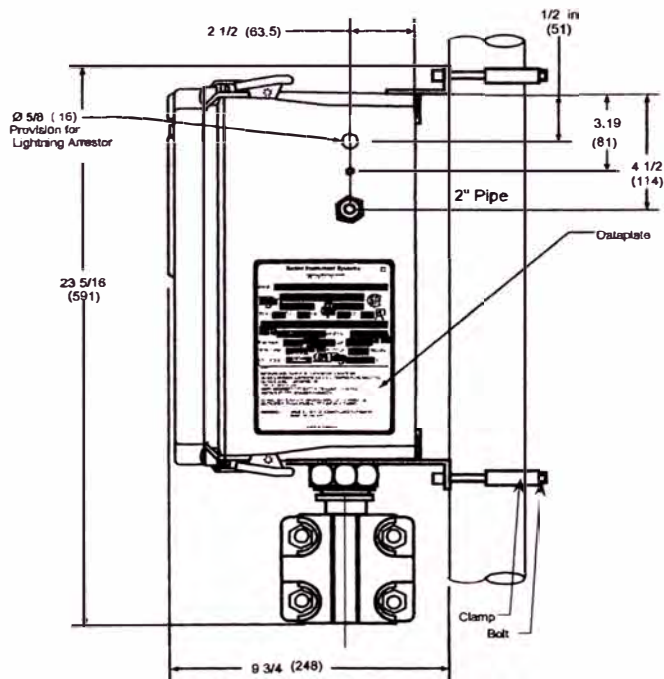

2. DPE mounting standard 2-1/8 spacing 1/4" NPT process connections.  
 Notes: 1. All dimensions in inches fraction  $\pm 1/32"$ , 0.XX  $\pm 0.01"$ , 0.XXX  $\pm 0.005"$

# Scanner 1131S

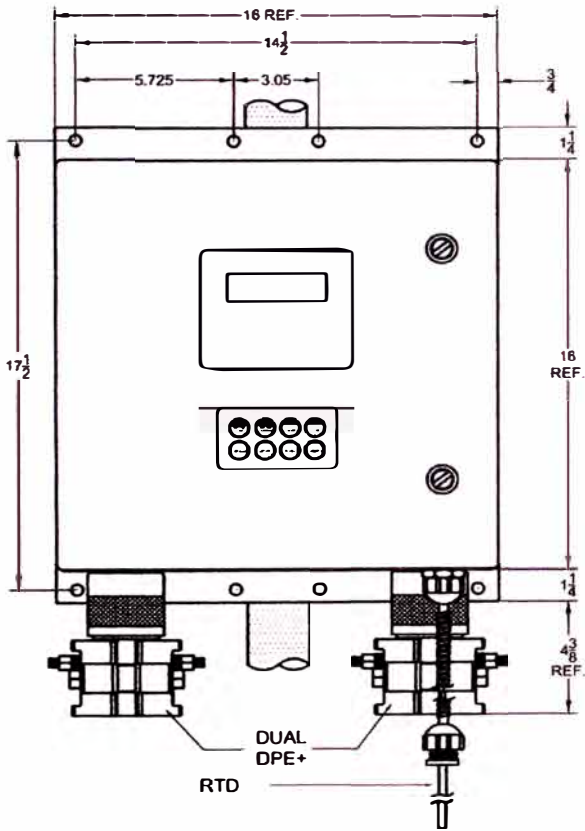

FRONT VIEW

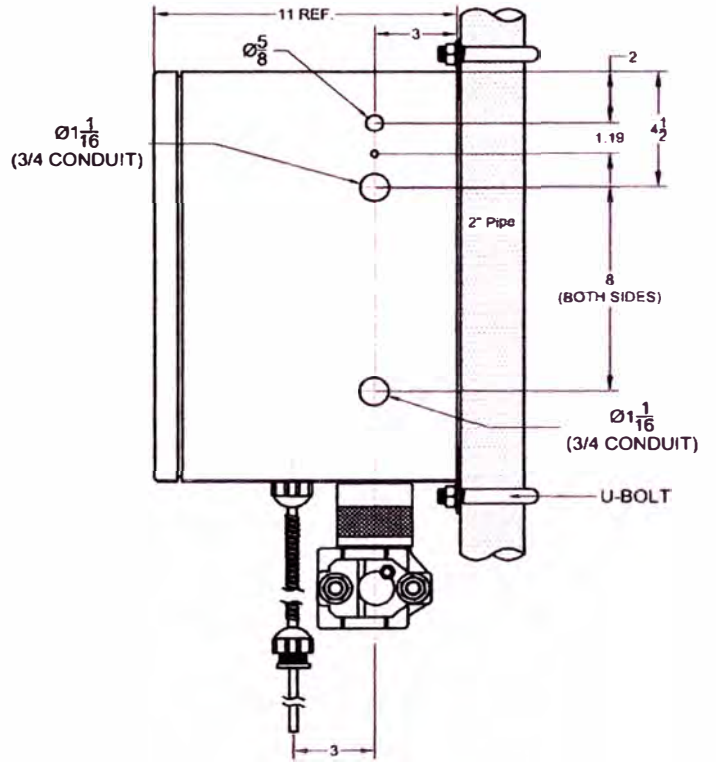

RIGHT SIDE VIEW

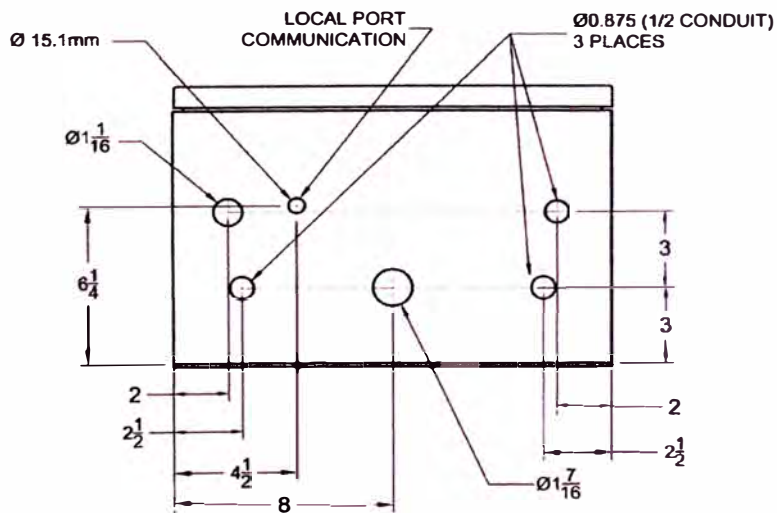

BOTTOM VIEW  
(NO DPE+)

## **Anexo 3: Información Técnica Caudalímetro Másico Térmico**

**ST-75V**



## ST75/ST75V MASS FLOW METER Installation and Operation Guide

### Pre-Installation

#### Serial Number Alignment

The ST75 and ST75V (Vortab) can be specified with integral or remote electronics. The flow element has a serial number etched into the side of the HEX as shown on figure A. In addition, the tag on the enclosure will also denote serial number and model number. The associated transmitter circuit card has a serial number noted on the board as shown in figure B. The flow sensor and transmitter circuit have been calibrated as a matched set and should be paired together in service unless otherwise approved by a factory technician.

#### Flow Direction Alignment

All sensor elements have a flow arrow indicator marked on the element assembly at the reference HEX flat. These flow elements have been calibrated in a particular direction and are designed to be used in service with the flow arrow going in the same direction as flow in the pipe stream. The flow element has been calibrated directly in the pipe tee or tube tee with careful consideration for orientation and insertion depth. Removal from the tee section while physically possible is not recommended unless authorized by a factory technician.

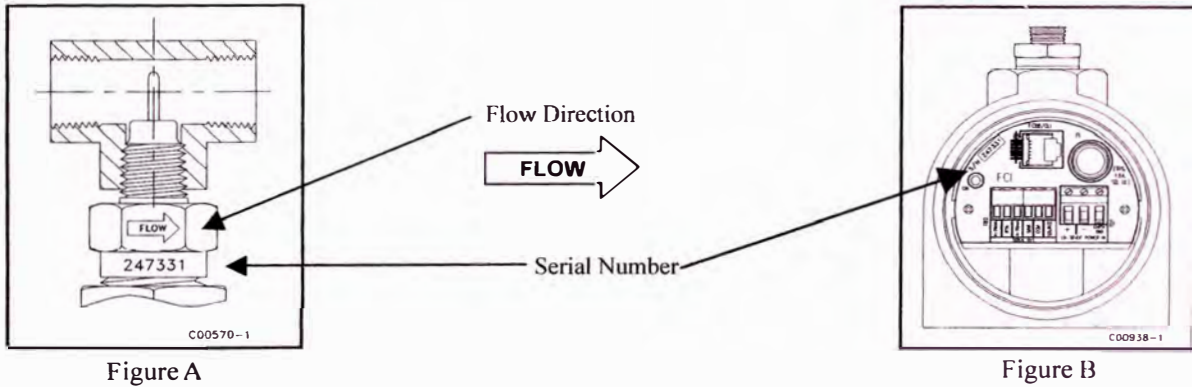

#### Recommended Straight Run

To optimize flow meter system performance, FCI recommends installation with a minimum of 20 diameters upstream straight run and 10 pipe diameters of downstream straight run. Where straight run limitations significantly reduce the available pipe diameters, FCI utilizes flow conditioners to produce a transferable flow profile from the calibration installation to actual field installations. FCI's proprietary AVAL software is available to make flow meter installation evaluations where straight run limitations are considered. See Figure C for recommended installation.

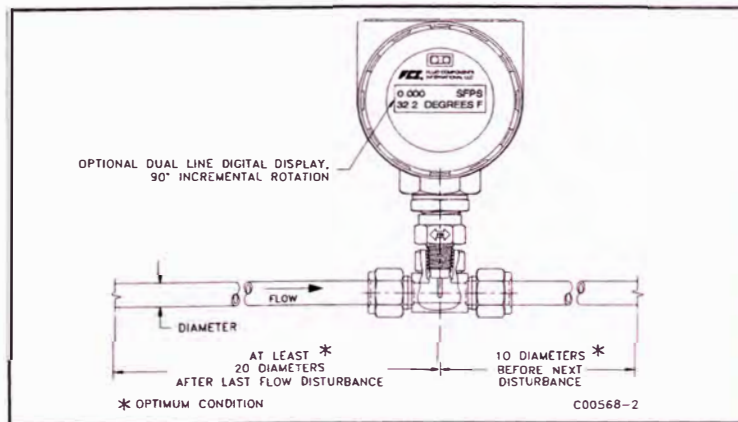

Figure C - Recommended Straight Run Condition

**Specifications**

**Media Compatibility:**

Air, compressed air, nitrogen, oxygen, argon, CO2, ozone, other inert gases, natural gas, and other hydrocarbon gases, hydrogen.

**Pipe/Line Size Compatibility:** 1/4" to 2" [6 mm to 51 mm]

**Instrument**

**ST75/ST75V Range:\***

Port Line Size	1/4"	1/2"	3/4"	1"	1 1/2"	2"
Min. SCFM	0.04	0.13	0.22	0.35	0.85	1.40
Min. [NCMH]	[0.07]	[0.22]	[0.38]	[0.59]	[1.44]	[2.38]
Max. SCFM	17.34	50.64	88.88	139.95	539.31	559.27
Max. [NCMH]	[29.47]	[86.04]	[151.00]	[237.78]	[576.48]	[950.20]

tubing Line Size	1/4"	1/2"	1"
Min. SCFM	0.01	0.05	0.25
Min. [NCMH]	[0.01]	[0.09]	[0.42]
Max. SCFM	3.02	21.15	99.08
Max. [NCMH]	[5.14]	[35.94]	[168.33]

*actual range subject to gas type and specific conditions.*

**Accuracy:**

ST75: ± 2% of reading, ± 0.5% of full scale  
 Optional: ± 1% of reading, ± 0.5% of full scale

ST75V: ± 1% of reading, ± 0.5% of full scale

**Repeatability:** ± 0.5% of reading

**Temperature Compensation:**

Standard: 40 to 100°F [4 to 38°C]  
 Optional: 0 to 250°F [-18 to 121°C]

**Turndown Ratio:** 10:1 to 100:1

**Agency Approvals:**

ATEX/IEC Ex: II 2 G Ex d IIC T6...T3  
 II 2 D Ex tD A21 IP67 T90°C...T121°C  
 FM, CSA: Class I, II, III, Div. 1, Groups B-G  
 Class I, Div. 2, Groups A-D  
 CRN No.: 0F0303

**Warranty:** One year

**Flow Element**

**Installation:**

ST75: In-line "T", NPT or tube

**Material of Construction:** All-welded 316 stainless steel probe element with Hastelloy-C thermowells; 316 stainless steel NPT and tube fittings

**Maximum Operating Pressure:**

ST75: T-fitting [NPT female]: 240 psi [16.5 bar(g)]  
 Tube: 600 psi [41 barg]  
 ST75V: 240 psi [16.5 bar(g)]

**Temperature:** Operating: 0 to 250°F [-18 to 121°C]

**Process Connection:**

ST75: T-fitting [NPT female]: 1/4", 1/2", 3/4", 1", 1 1/2" or 2"  
 Tubing: 1/4", 1/2" or 1"

ST75V: Female NPT, Male NPT, Flange  
 1/4", 1/2", 3/4", 1", 1 1/2" or 2"

**Transmitter**

**Enclosure:** NEMA 4X [IP67], aluminum, dual conduit ports with either 1/2" Female NPT or M20x1.5 entries. Epoxy coated.

**Output Signals:**

(2) 4-20 mA user assignable to flow rate and/or temperature  
 (1) 0-1 kHz pulse for total flow

**Communication Port:** RS232C standard. Optional wireless IR to PDA with digital display models

**Input Power:**

DC: 18 Vdc to 36 Vdc (6 watts max.)  
 AC: 85 Vac to 265 Vac (12 watts max.; CE Mark Approval for 100 Vac to 240 Vac)

**Operating Temperature Range:** 0 to 140°F [-18 to 60°C]

**Digital Display: (Optional)**

Two-line x 16 characters LCD. Displays measured value and engineering units. Top line assigned to flow rate. Second line is user assignable to temperature reading, flow totalizer or alternating. Display can be rotated in 90° increments for optimum viewing orientation.

DI Flow Meters may be installed with less than the recommended straight run, but may have performance limitations. FCI offers ORTAB flow conditioners for use in applications that have significant straight run limitations. FCI uses the AVAL application modeling software to predict meter performance in each installation. AVAL outputs are available to review prior to order placement and will indicate performance expectations both with and without flow conditioning.

### **Flow Element Installation**



**Warning:** The element is shipped specifically installed in the TEE oriented for inline installation. DO not remove the sensing element from the TEE section during installation as calibrated performance can be effected.

### **Process Connections**

The ST75 is available in pipe Tee configurations with NPT threads and tubing tees with a compression fitting suitable to clamp down on concentric smooth surface tubing. The pipe Tee versions are standard 150# class rated tees suitable for service up to 150 PSIG at the process temperature maximum of 250°F (121°C). The compression fitting material offered in the tube type configuration is rated for 50 PSIG service.

**Pipe Tee Installation:** With pipe extensions properly cut to length and the appropriate sealing materials used on the threads, install flow element section by slowly rotating the configuration until firmly secure on the pipe section. Complete by installing opposing end pipe section using care to firmly secure the element assembly either in a top mount or side mount position.

**Tube Tee Installation:** Clean all mating surfaces of the tee fitting, ferrules and the flow tube. Insert the flow tubing into the tee fitting. Make sure the tubing rests firmly in the fitting counter bore seat. Tighten the nut on both ends of the tee by hand. Hold the fitting body steady with a backup wrench, tighten the fitting nuts 1-1/4 turns, from hand tight baseline.

The ST75V is available in with flow tube configurations offering male and female NPT threads, ANSI flanges and DIN flanges. The flow tube assemblies are rated for service up to 240 PSIG at the process temperature maximum of 250°F (121°C).

**NPT Flow Tube Installation:** With pipe extensions properly cut to length and the appropriate sealing materials used on the threads, install flow element section by slowly rotating the configuration until firmly secure on the pipe section. Complete by installing opposing end pipe section using care to firmly secure the element assembly either in a top mount or side mount position.

**Flanged Installation:** Clean all mating surfaces. Install appropriate sealing gasket between mating flanges. Tighten flange mating hardware to meet system sealing requirements.

See Appendix C for instrument outline dimensional details.

## **Instrument Wiring**

Before the instrument is opened to connect power and signal, FCI recommends that the following ESD precautions be observed:

Use a wrist band or heel strap with a 1 megaohm resistor connected to ground. If the instrument is in the shop setting, there should be an antistatic conductive mat on the work table or floor with a 1 megaohm resistor connected to ground. Connect the instrument to ground. Apply antistatic agents such as Static free made by Chemtronics (or equivalent) to hand tools to be used on the instrument. Keep high static producing items away from the instrument.

The above precautions are minimum requirements. The complete use of ESD precautions can be found in the U.S. Dept of defense Handbook 263.



**Warning:** Only Qualified personnel are to wire or test this instrument. The operator assumes all responsibility for safe practices while wiring and trouble shooting.

FCI recommends installing an input power disconnect switch and fuse near the instrument to interrupt power during installation and maintenance. Operator must have power disconnected before wiring.

See Safety instructions in Appendix A for the use of the ST75/ST75V series (AC and DC versions) in Hazardous Areas Category II (Zone 1). Approval, KEMA 08ATEX0045/IECEX KEMA08.0012 for Category 2 GD protection Ex d IIC T6..T1, Ex tD A21 IP67 T 90°C...T 121°C.

## **Input Power**

The ST75/ST75V is available with both VDC and VAC input power configurations. Customers selecting VDC input power will have a VDC input board only. Similarly, the VAC power board is supplied only with VAC powered units. In addition, both boards are marked for either AC or DC power. Only connect the power specified on the wiring module as shown on Figures E and F respectively. Both VAC and VDC inputs require a Gnd wire to be connected. Input power terminal blocks are rated for 14-26 AWG.

To wire the instrument, ensure that the power is off. Pull the power and signal output wires through the port, using care not to damage wires. FCI recommends using crimp lugs on the output wires to ensure proper connection with the terminal strip. Connect the output wires as shown on figures E and F. Note that when the 4-20mA outputs are used simultaneously, a single return lead is used.

## **Analog Output**

**4-20mA:** The instrument is provided with a standard set up, of two 4-20mA outputs. Output 1 configured for flow and Output 2 configured for temperature. Terminal blocks rated for 14-28 AWG., 500 ohm max load per output.

**Pulse Output Activation**

The ST75/ST75V provides a pulse output feature. Instruments ordered with volumetric or mass flow units will be factory set with analyzer and pulse output activated. The mode can be changed in the field. Wiring either sink or source mode is shown in Figures E and F below. Though only one configuration is shown with the VAC and VDC power supplies, the source or sink can be utilized with either power input.

**Sink Mode:** 40 VDC Max, 150 mA max. Customer supplied power source

**Source Mode:** 15 VDC output, 50 mA max

**VDC Power Connection**

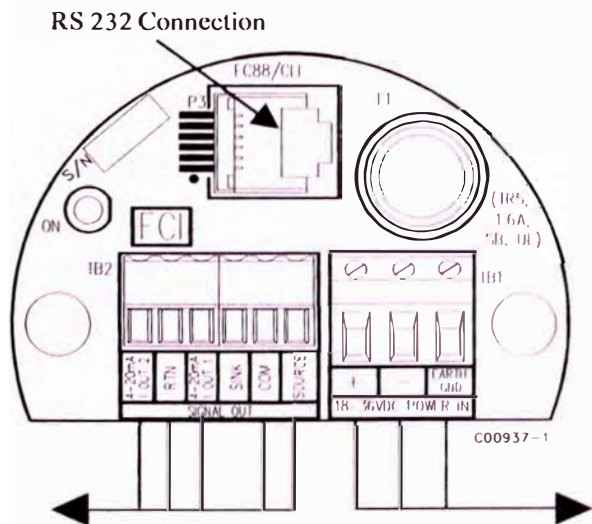

Figure E

**VAC Power Connection**

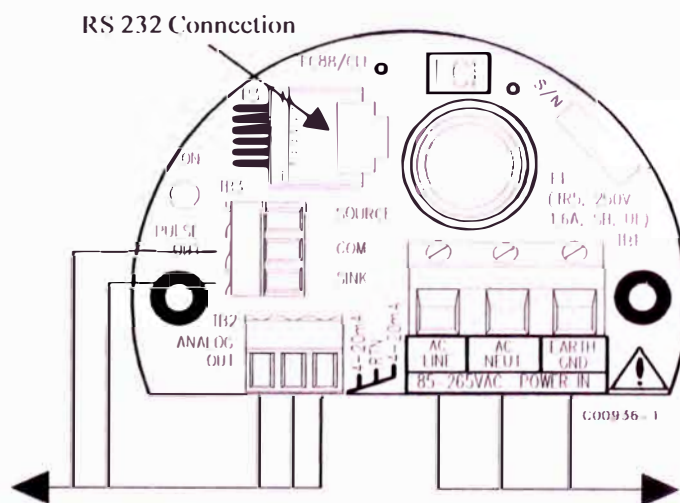

Figure F

**VDC Power**

As Shown:

18-36VDC power connected with gnd  
4-20mA connected for flow and temperature  
Pulse Out in source mode

**Note:** In source mode, 15VDC Output max, 50mA max.

**VAC Power**

As Shown:

85-265 VAC power connected with gnd  
4-20mA connected for flow and temperature  
Pulse Out in sink mode

**Note:** In sink mode, 40VDC max, 150mA max customer supplied power source.

**Power Dissipation**

**AC Version**

Power dissipation values under nominal conditions:

Instrument (Electronics + Sensor): 11.6 Watts

Sensor only: 0.25 Watts

Power dissipation values under maximum load conditions:

Instrument (Electronics + Sensor): 12 Watts

Sensor only: 0.30 Watts

**DC Version**

Power dissipation values under nominal conditions:

Instrument (Electronics + Sensor): 4.5 Watts

Sensor only: 0.25 Watts

Power dissipation values under maximum load conditions:

Instrument (Electronics + Sensor): 6 Watts

Sensor only: 0.30 Watts

**Setup Interface**

All parameters on this meter are set through the RS232 interface connection (P3 plug) or PDA IR interface. A jumper selection determines which communication mode is active. The factory default communication mode is set for the RS232 interface. This setting allows the instrument to be setup with either a FC88 hand held communicator or a computer. The FC88 is powered through the meter and comes with the serial interface cable. If a computer interface is used, an adapter (RJ to 9 pin Computer Serial Port) is required and may be obtained from FCI: Part No. 014108-02.

Using Windows Terminal (usually located in Accessories) execute the program by double-clicking on the Terminal Icon.

Go to *Settings*.

Click on *Communication*.

Set for COM1 or COM2, 9600 Baud, 8 Bit, and No Parity. Press OK

Press the *ENTER* key to see the *Input Mode?* prompt.

Enter any of the meters single letter commands to execute a function (reference complete function menu in Appendix B).

If the PDA IR interface is used for communication, then jumper JP5 needs to be moved to the alternate position, see Figure G and H. See the PDA IR Communication Interface section for more details.

An additional command line interface (CLI) is available through the RS232 port. This interface is accessed with the “Y” command using a computer or FC88. The command line password is “357”. See Appendix B - Table 6 for command line details.

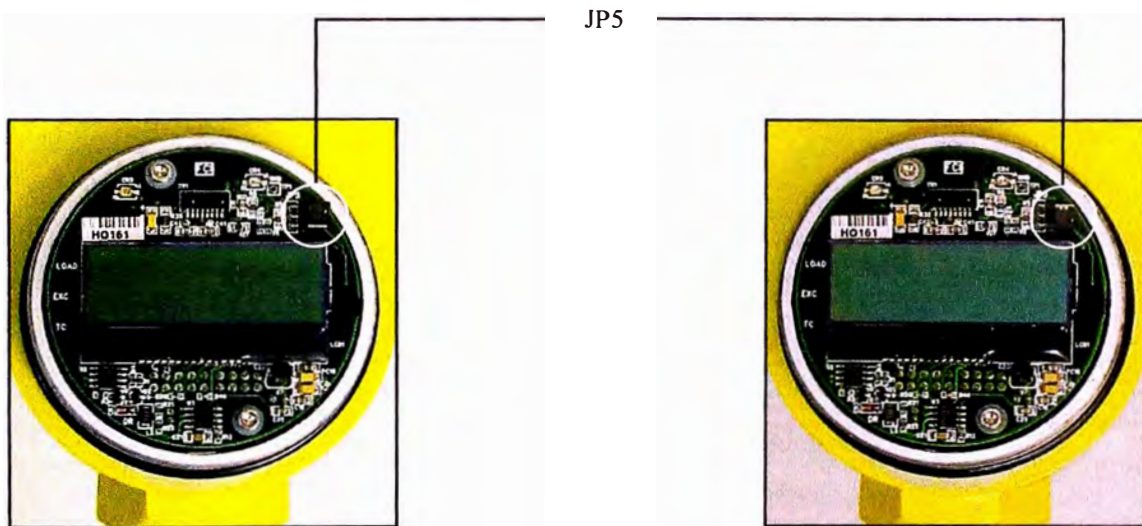
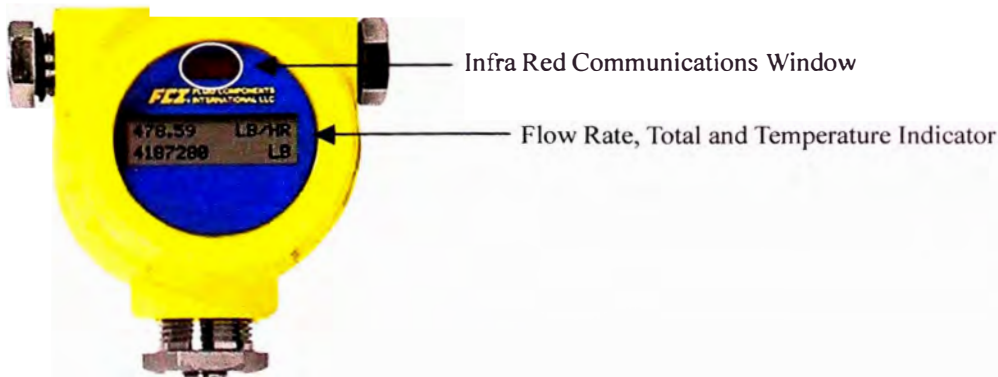

Figure G  
JP5 factory set for RS232 interface

Figure H  
JP5 set for PDA IR interface



## Start up and Commissioning

- 1 Verify all Input power and output signal wiring is correct and ready for initial power start up.
- 2 Apply power to instrument. The instrument will initialize in the Normal Operation Mode. All outputs will be active and instruments with the display option will indicate flow with the factory set flow unit. Allow 10 minutes for the instrument to warm up and come to the thermal equilibrium.

The following FC88 commands are typical commands that are used during start up and commissioning:

Command	Name	Description
T	Normal Operation Mode	All outputs are active
Z	Flow Unit Set-Up	Select Flow Units(4 English, 4 Metric)Pipe Dimensions
W	Totalizer	Enable/Disable
V	Output Configuration	Select one of 4 Configurations: Pulse and/or AlarmPulse factor and/or setpoint
F	K-Factor (default=1)	Flow factor
N	Warm Re-set	Re-initialize C/B
S	Totalizer Menu	Enables W menu (Option)

the instrument is installed, and the process flow is zero, the instrument should indicate 0.000.

### Flow Unit Modification

Example: SCFM Flow Units and 3 inch Sch 40 round pipe size set up:

Enter	Display	Description
Enter	menu: >	From Normal Operation Mode
Z	E for English M for Metric >	Flow Unit Set-Up menu
E	0=SFPS, 1=SCFM, 2=SCFH, 3=LB/H, 4=GPM #	English units
1	R round duct or S rectangular>	Select Standard Ft./Min (SCFM)
R	Dia.: 4.0260000 Change? (Y/N)>	Select Round Duct
Y	Enter value: #	
3.068	area: 7.3926572 CMinflow: 0.0000000 Change? (Y/N)>	3 inch Sch. 40 pipe I.D.
N	Maximum flow: 462.04 Enter to continue	
Y	Cmaxflow: 462.04 Change? (Y/N)>	
Y	#	
462.04	CMintemp (F): -40.00000 Change? (Y/N)>	
N	CMaxtemp (F): 250.00000 Change? (Y/N)>	
N	Percent of Range is: OFF Change to ON?>	
N	LCD Mult Factor x1 Change? (Y/N)>	
N	100.0 SCFM	Instrument will end up in Normal Operation Mode

**S232 / FC88**

**Menu Control and Organization**

Most entries require at least two key strokes; a Capital letter and the [ENTER] key, or one or more numbers and the [ENTER] key. All letter entries begin at the input mode prompt ">", except when the instrument is in the Main Function Mode (just press the desired function letter and [ENTER] to make an entry).

Backspaces are made using the backspace [BKSP] key. Some entries are case sensitive between numbers and letters. Be sure the SHIFT key is pressed to indicate the correct case. A square after the prompt caret indicates the FC88 is in lower case. A slightly raised rectangle in the same spot indicates the FC88 is in the upper case.

It is recommended that the FC88 be plugged into the instrument before power is applied. If the FC88 is plugged in while the instrument power is on and the FC88 does not respond, press [ENTER], if there is still no response Press [N] or cycle the power.

**Note:** The Zero and Span may be changed from the original calibration, provided the new values are within the original calibrated range. i.e. If the original calibration was 1 to 100 SCFM (4-20mA), the new zero (4mA) must be equal to or greater than 1 SCFM, the new span (20mA) must be equal to or less than 100 SCFM.

Some entries require a Factory pass code. If this occurs contact FCI Field Service to continue programming the instrument. The instrument will prompt the user when this is necessary. Do not change any parameters that require this code unless there is an absolute understanding of the instrument's operation. The user can not exit some routines unless all entries are completed or the power is cycled.

The top level of the menu is shown in Appendix B - Table 5. Enter the large letter in the tables below to activate a command. The user may exit a command at any time entering "Q" [ENTER] in the menus: D, K, V, W, or Z.

<b>D Calibration Information</b>	Display only: A/D, Delta-R, Ref-R data values
<b>D Diagnostics</b>	Display only: List of unit parameters.
<b>K Factory Calibration Settings</b>	Display only: Cal. parameters, i.e. linearization and temperature compensation coefficients.
<b>R Factory Reset</b>	Replaces user data with factory calibration data

**Table 1. Diagnostics and Factory Settings**

Units		
Select	E=English	M=Metric
Select	0= SFPS	5 = SMPS
or	1 = SCFM	6 = NCMH
or	2 = SCFH	7 = NCMM
or	3 = LBS/H	8 = KG/H
or	4 = GPM	9 = LPM
For Volumetric or Mass Flow		
Select	R = Round pipe or duct	
or	S = Square duct	
Set	Diameter or Wide X High (in inches or mm)	
Set	CMaxflow = Maximum flow rate (span)	
Set	CMinflow = Minimum flow rate (zero)	
Note: Changing units requires rescaling the unit (set new zero and span)		

**Table 2. "Z" Flow Units Set-Up and Scaling**

<b>Analog out</b>					
	Select	<u>1</u>	<u>2</u>	<u>3</u>	<u>4</u>
4-20mA out 1		Flow	Flow	Temp	Temp
4-20mA out 2		Temp	Flow	Flow	Temp
<b>Pulse out</b>					
	Select	<u>1</u>	<u>2</u>	<u>3</u>	<u>4</u>
Source out		Pulse	Pulse	Alarm0	Alarm0
	Set	Factor	Factor	Set pt.0	Set pt.0
	Set	Period	Period	State0	State0
	Set	State0	State0		
Sink		Pulse	Alarm1	Pulse	Alarm1
	Set		Set pt.1	Factor	Set pt.1
	Set	State1	State1	Period	State1
				State1	

**Table 3. "V" Output Configuration Set-Up**



**7” Menu Output Configuration Set Up**

**NOTE:** The display comes up to the last setting saved and stays for 2 seconds. If **N** or **[ENTER]** is entered, the menu proceeds to the Pulse out. If **Y** is entered, the display moves to the selection options and/or asks for confirmation. If you miss the option, select **[Enter]** repeatedly to loop around.

<p><b>Output Mode</b> Selected</p> <p>20mA #1: Flow 20mA #2: Temp</p> <p>Change? (Y/N)&gt;</p> <p>4-20mA #1: Flow 4-20mA #2: Temp Enter 1 to make the selection__</p> <p>4-20mA #1: Flow 4-20mA #2: Temp Enter 2 to make the selection__</p> <p>4-20mA #1: Temp 4-20mA #2: Flow Enter 3 to make the selection__</p> <p>4-20mA #1: Temp 4-20mA #2: Temp Enter 4 to make the selection__</p>	<p><b>Pulse out</b> Pulse Out Selected</p> <p>Source: Pulse Sink: Pulse</p> <p>Change? (Y/N)&gt;</p> <p>Source: Pulse Sink: Pulse Enter 1 to make the selection #__</p> <p>Source: Pulse Sink: Alarm1 Enter 2 to make the selection #__</p> <p>Source: Alarm0 Sink: Pulse Enter 3 to make the selection #__</p> <p>Source: Alarm0 Sink: Alarm1 Enter 4 to make the selection #__</p>	<p>PFactor: 1.000 Change? (Y/N)&gt; if yes Enter new factor: ____</p> <p>Sample Period: 1 second Change? (Y/N)&gt; if yes Enter new Sample Period: ____</p> <p><i>If alarm is a selected output</i> Set point1: 000 Set points are in the same units as the flow or temp.</p> <p>Change? (Y/N)&gt; if yes Enter new set point: ____ Resume normal operation</p> <p>Source state: High to Low</p> <p>Change to Low to High?&gt;</p>
--	--	--

**Example: COMMAND V (Reference Table 3)**

Case: 4-20mA #1 = flow, 4-20mA #2 = Temperature, Source Out = Pulse, Sink = Alarm

Pressing **[V]** **[ENTER]** will display  
 “4-20mA #1 = Flow”  
 “Change? (Y/N)”  
 Press **[ENTER]** (no change).

The last saved mode will display at this point. i.e.,

“Source: Pulse”	“Sink: Pulse”	followed by,
“Change? (Y/N)”	Select <b>Y</b> <b>[Enter]</b> .	The display reads,
“Source: Pulse”	“Sink: Pulse”	followed by,
“Enter 1 to make the selction #.”	Select <b>[ENTER]</b> .	The next display reads,
“Source: Pulse”	“Sink: Alarm”	followed by,
“Enter 2 to make the selction #.”	Select <b>2</b> and <b>[ENTER]</b> .	The next prompt reads,
“PFactor: 1.000”	“Change? (Y/N)>”	(this factor can be anywhere from 0.001 to 1000 - A pulse factor of 1.000 will output 1 pulse per unit of flow.)

If no change, select **N** and/or **[ENTER]** to continue.  
 The next prompt is, “Sample Period”  
 “Change? (Y/N)>” (this value may be set from 0.5 to 5 seconds)

If no change, select **N** and/or **[ENTER]** to continue.  
 The next prompt is, “Source state: ” “High to Low” Change to “Low to High?>” (this selection toggles the pulse signal normally high or normally low).

**[ENTER]** to read display.  
 “Switchpt1” “0.000000” the current set point.  
 “Change? (Y/N)>” enter **Y** **[ENTER]** and enter # \_\_\_\_ . Set Point Value , i.e. 50 (value is in same units as the flow and must be within the calibrated range). **[ENTER]**. The next prompt is,  
 “Sink state: ” “High to Low” Change to “Low to High?>”. Set the output signal to be normally “High” or normally “Low.” Pressing **[Y]** **[ENTER]** toggles the current setting. Pressing **[ENTER]** resumes normal operation.

## PDA IR Communication Interface

The IR interface software is an optional accessory kit and can be ordered using FCI part number 019819-01. The software is compatible with PALM OS 4.1 or greater. If the software was ordered with the instrument, a CD should be located with the instrument documentation.

The factory has verified the following 3 PDA models. All commands meet their intended purpose and function properly.

- Palm, Tungsten E, E2: Palm OS 5.2.1, 5.4.7
- Palm, Zire 71, Palm OS 5.2.1
- ecom instruments, m 515-EX, Intrinsically-safe. Palm OS 4.1

### Procedure:

- Download the software into the target PDA. When complete, a yellow and blue FCI icon will be available.
- Verify JP5 jumper is set in the PDA IR interface position, see Figure H.
- Select FCI icon on PDA device.
- The opening menu is displayed, select start.
- Five menu groups are displayed.

**Process:** displays current process variables (Flow and Temperature)

**ID-Unit:** displays model, firmware version, serial no. ...

**Set-up:** allows access to the following areas

Units	K Factor
Line size	Temp/Flow min/max
Totalizer	Output Cal
LCD	Output Config

**Diagnostics:** A/D values

**Utilities:** allows access to the following areas

- Reset
- Parameter memory
- Calibration coefficients
- Factory restore
- Process and System Faults

- After entering into specific menu areas, point the PDA IR port towards the Instrument display. Begin with the PDA device within 5 feet of the instrument display. Select the "Get All" or "Get" button to retrieve information from the instrument. If a value needs to be changed, the value must first be retrieved.

**Example:** reading standard process variable information

- Verify instrument and PDA are functioning.
- Select FCI icon on the PDA.
- Select the start button on the opening screen.
- Select the "Process" button.
- Point the PDA at the instrument display, start with the PDA no further than 5 feet from the instrument.
- Select the "Get Data" button.
- Flow and temperature Data will begin streaming to the PDA.
- If the IR link is interrupted, a "Command response timed out" message will be displayed.
- Repeat the process if the link is interrupted.

## **Maintenance**

The FCI instrument requires little maintenance. There are no moving parts or mechanical parts subject to wear in the instrument. The sensor assembly which is exposed to the process media is composed of 316 SS and Hastelloy C.

Without detailed knowledge of the environmental parameters of the application surroundings and process media, FCI cannot make specific recommendations for periodic inspection, cleaning, or testing procedures. However, some suggested general guidelines for maintenance steps are offered below. Use operating experience to establish the frequency of each type of maintenance.

### **Calibration**

Periodically verify the calibration of the output and recalibrate if necessary. FCI recommends every 18 months at a minimum.

### **Electrical Connections**

Periodically inspect cable connections on terminal strips and terminal blocks. Verify that terminal connections are tight and physically sound with no sign of corrosion.

### **Remote Enclosure**

Verify that the moisture barriers and seals protecting the electronics in the local enclosure is adequate and that no moisture is entering the enclosure.

### **Electrical Wiring**

FCI recommends occasional inspection of the system's interconnecting cable, power wiring and flow element wiring on a "common sense" basis related to the application environment. Periodically the conductors should be inspected for corrosion and the cable insulation checked for signs of deterioration.

### **Flow Element Connections**

Verify that all seals are performing properly and that there is no leakage of the process media. Check for deterioration of the gaskets and environmental seals used.

### **Insertion Type Flow Element Assembly**

Periodically remove the flow element for inspection based on historical evidence of debris, foreign matter, or scale build-up and appropriate plant shutdown schedules and procedures. Check for corrosion, stress cracking, and/or build-up of oxides, salts, or foreign substances. The thermowells must be free of excessive contaminants and be physically intact. Any debris or residue build-up could cause inaccurate flow indication. Clean the flow element, as necessary, with a soft brush and available solvents (compatible with Stainless Steel).

**Troubleshooting**

**Application Verification**

After verifying that the flow meter is functioning, review the application parameters as shown below to verify the calibration matches the process media.

**Equipment Needed**

- Flow Instrument Calibration Data
- Process Parameters and Limits

**Check Serial Numbers**

Verify that the serial number of the flow element and the flow transmitter electronics are the same. The flow element and the flow transmitter are a matched set and cannot be operated independently of each other.

**Check the Instrument Installation**

Verify correct mechanical and electrical installation. Verify the flow element is mounted at least 20 diameters downstream and 10 diameters upstream from any bends or interference in the process pipe or duct.

**Check for Moisture**

Check for moisture on the flow transmitter. Moisture may cause intermittent operation. Check for moisture on the flow element. If a component of the process media is near its saturation temperature it may condense on the flow element. Place the flow element where the process media is well above the saturation temperature of any of the process gases.

**Check Application Design Requirements**

Application design problems may occur with first time application instruments, although the design should also be checked on instruments that have been in operation for some time. If the application design does not match field conditions, errors occur.

1. Review the application design with plant operation personnel and plant engineers.
2. Ensure that plant equipment such as pressure and temperature instruments conform to the actual conditions.
3. Verify operating temperature, operating pressure, line size, and gas medium.

**Verify Standard Versus Actual Process Conditions**

The flowmeter measures the mass flow rate. The mass flow rate is the mass of the gas flowing through a pipe per time. Other flow meters, such as an orifice plate or a pitot tube, measure the volumetric flow rate. The volumetric flow rate is the volume of gas per time. If the readings displayed do not agree with another instrument, some calculations may be necessary before comparing them. To calculate the mass flow rate, the volumetric flow rate, and the pressure and temperature, the point of measurement must be known. Use the following equation to calculate the mass flow rate (Standard Volumetric Flow rate) for the other instrument:

**Equation:**

$$Q_s = Q_A \times \frac{P_A}{T_A} \times \frac{T_s}{P_s}$$

Where:

- $Q_A$  = Volumetric Flow
  - $Q_s$  = Standard Volumetric Flow
  - $P_A$  = Actual Pressure
  - $T_A$  = Actual Temperature
  - $P_s$  = Standard Pressure
  - $T_s$  = Standard Temperature
- PSIA and °R are used for pressure and temperature units.

(Metric: Where bar(a) and °K are used for pressure and temperature.)

**Example:**

- $Q_A$  = 1212.7 ACFM
- $Q_s$  = 1485 SCFM
- $P_A$  = 19.7 PSIA
- $T_A$  = 120°F (580°R)
- $P_s$  = 14.7 PSIA
- $T_s$  = 70°F (530°R)

(Metric:  $P_s$  = 1.01325 bar(a)  
 $T_s$  = 21.1°C (294.1K))

$$\left( \frac{1212.7 \text{ ACFM}}{1} \right) \left( \frac{19.7 \text{ PSIA}}{580^\circ \text{ R}} \right) \left( \frac{530^\circ \text{ R}}{14.7 \text{ PSIA}} \right) = 1485 \text{ SCFM}$$

**Calibration Parameters Verification**

The instrument uses a set of predetermined calibration parameters to process flow signals. Most of these parameters should not change. A data package located with this manual contains the “ST75/ST75V Delta R Data Sheet”. This contains the calibration parameters stored in the flow transmitter at the factory. To verify that these parameters have not changed, complete the following:

1. Identify the appropriate Delta R Data sheets by serial number of the instrument.
2. Press [D] [ENTER] to examine each of the parameters. The [ENTER] key allows scrolling one message at a time. Use Table 4 to verify parameters with the Delta R Data sheet ST75/ST75V Parameters.

S/W Version:		dR Min:		T SpanIDAC 0:	
Flow Factor:		dR Max:		T ZeroIDAC 0:	
Cmin Flow:		Cal Ref:		T SpanIDAC 1:	
Cmax Flow:		Tcslp:		T ZeroIDAC 1:	
Eng Units:		Tcslp 0:		State 0:	
Line Size 0:		Tcslp 2:		Switch Pt 0:	
Line Size 1:		Tot Menu:		State 1:	
Cmin Temp:		Tot Flag:		Switch Pt 1:	
Cmax Temp:		Totalizer:		K factor 1:	
Min Flow:		Rollover Cnt:		K factor 2:	
Max Flow:		Fix Pt Flag:		K factor 3:	
Density:		Pulse Factor:		K factor 4:	
*C1 [1]:		Pulse Out:		I factor:	
*C1 [2]:		Hours:		Temp Flag:	
*C1 [3]:		Sample Period:		Out Mode:	
*C1 [4]:		dR Slope:		Boxcar Max:	
*C1 [5]:		dr Off Set:		RTD-SLP-385:	
Break Pt:		Refr Slope:		% of Range:	
*C2 [1]:		Refr Off Set:		User Name:	
*C2 [2]:		SpanIDAC 0:		Shop Order #:	
*C2 [3]:		ZeroIDAC 0:		Serial No.:	
*C2 [4]:		SpanIDAC 1:		Mode#:	
*C2 [5]:		ZeroIDAC 1:			

**Table 4. Diagnostic Test Sequence on Display**

Parameters that have an asterisk (\*) have changed, this may indicate a problem. Customer Service should be contacted. If the parameters have not changed, continue with the next section.

**Hardware Verification**

Equipment Required:

Digital Multimeter

Screw Driver

The ST75/ST75V Flowmeter is comprised of 4 basic components:

- 1 Sensor element.
- 2 Customer interface circuit board
- 3 Control circuit assembly circuit board module.
- 4 Electronics enclosure.

**Step 1**

Verify fuse (F1) located on the customer interface circuit board is in normal working condition.

Remove power from the instrument. Open the electronics enclosure exposing the customer interface circuit board. This circuit board is located under the shorter enclosure lid along with all of the power and input/output connections. Unscrew the clear cover on the fuse and pull the fuse out of the fuse holder. Check the fuse for continuity. If fuse reads open, replace with equivalent component (Wickmann Inc. part no. 019933-01), Wickmann Inc. series 374, amp code 1160, package 41.

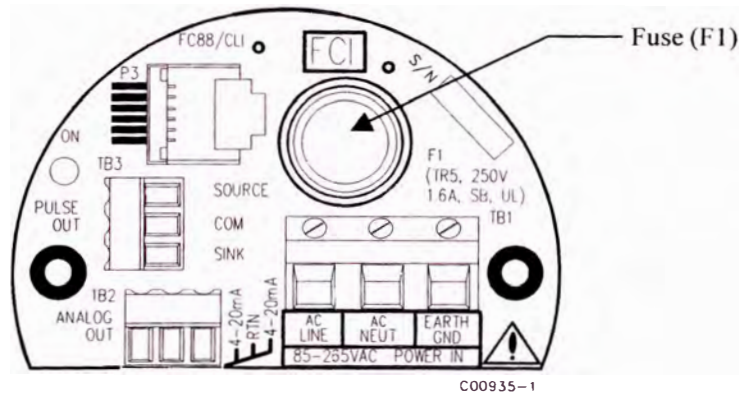

For DC power customer interface circuit board shown. Fuse (F1) on DC power customer interface circuit board located in similar position.

**Step 2**

Verify interconnecting cable from the customer interface board and the control circuit board assembly module are correctly seated into the appropriate header.

Remove power from the instrument. Open the electronics enclosure exposing the customer interface circuit board. This circuit board is located under the shorter enclosure lid along with all of the power and input/output connections. Remove the 2 screws securing the customer interface circuit board to the electronics enclosure. Carefully lift the interface face board exposing the interconnecting cable between the interface board and the control circuit assembly. Verify cable is seated firmly at both ends of the cable header.

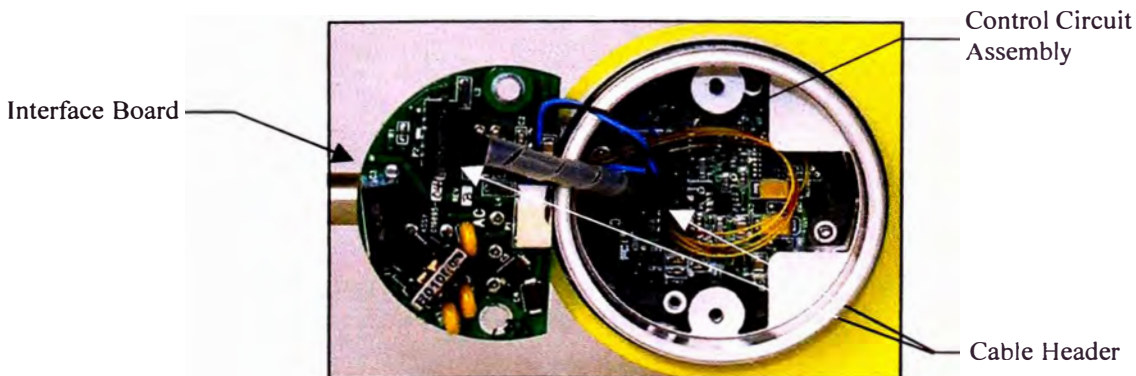

§ p 3

Verify sensor element continuity and resistance.

1. Move sensor element cable from the bottom of the control circuit assembly. Note that 2 of the wires have a red stripe and are located closest to the interconnecting cable header. Using an ohm meter verify that resistance between the 2 red striped wires is approximately 1100 ohms +/- 20. This resistance is temperature dependant. The resistance at 70 degrees F should be 1082 ohms. Verify the resistance between the 2 natural colored wires are approximately the same.

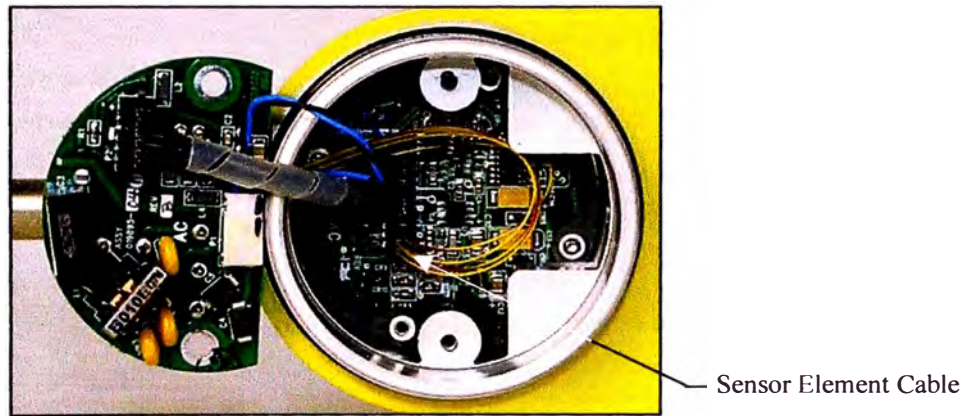

FCI provides full in-house technical support. Additional technical representation is also provided by FCI field representatives. Before contacting a field or in-house representative, please perform the troubleshooting techniques outlined in this document. If problems persist, contact the FCI Customer Service department at 1-800-854-1993 or 1-760-744-6950.

If the instrument is to be returned to FCI, please obtain an Return Authorization. The form contains a declaration of decontamination cleaning information that the instrument must comply with before it is shipped to FCI.

**Transmitter Circuit Calibration Check (Delta R Verification)**

**References**

Delta 'R' Data Sheet

**Equipment**

FC88 Communicator or equivalent.

DMV

Delta R Data Sheet-Match by serial numbers

2 Precision Decade Resistance boxes, 0.1% (Largest steps: 1K Ohm, smallest steps 0.01 Ohms)

Small flat Blade Screwdriver, 3/32 inches wide blade

FCI Normalization Cable, FCI part number 006407

**Procedure**

Verify all "D" mode calibration parameters are correct according to the meters Delta R Data Sheet, before starting verification.

Turn power off

Mark all sensor element wires connected to the circuit board, so they may be reconnected to the proper terminals. Disconnect the wires.

Connect the resistance decade box to the electronics as per the appropriate diagram for the ST75/ST75V.

**OTE: Interconnector wiring (resistance decade box to electronics) must be 24 AWG and 45 inches long, to avoid any inaccuracies in the Delta R verification, caused by improper wire lengths or wire gauges.**

Set both decade boxes for the nominal resistance value (1000 ohms) +/- .01%

Connect DVM to the meters output termination and monitor the meter output.

Turn the power ON and allow the instrument 5 mins. To stabilize

With the FC88 connected, Press [T] [Enter] to view the Normal Operating Mode.

Adjust the Active Decade Box (Reference decade box remains fixed @ 1000 ohms) to achieve the appropriated Delta R for the displayed flow value and output, noted on the meters Delta R Data Sheet.

2. Note the [C] mode and verify the meters displayed TCDR and REFR values corresponding to the displayed flow rate as per the meters Delta R Data Sheet.

1. Return to the [T] mode to continue the verification.

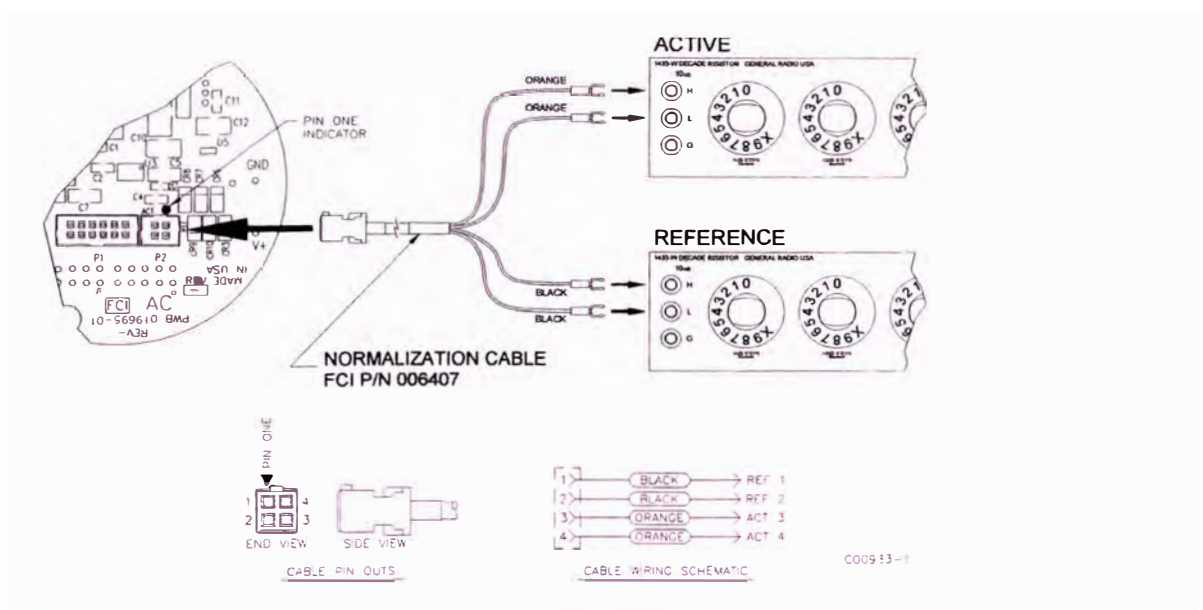



# Appendix A - Approval Information

## EC Information



### EC DECLARATION OF CONFORMITY Model ST51 / ST75

We, *Fluid Components International LLC*, located at 1755 La Costa Meadows Drive, San Marcos, California 92078-5115 USA, declare under our sole responsibility that the **ST51/ST75 Flowmeter Product Family**, to which this declaration relates, are in conformity with the following standards and Directives.

#### Directive 94/9/EC ATEX IECEX Scheme

Certified by KEMA Quality B.V. (0344): Utrechtseweg 310, 6812 AR, Arnhem, The Netherlands

EC-Type Examination Certificates:

KEMA 08ATEX0045 satisfies EN 60079-0: 2006, EN 60079-1: 2004, EN 61241-0: 2006, EN 61241-1: 2004 requirements for use in hazardous areas.

IECEX KEMA08.0012 satisfies IEC 60079-0: 2004, IEC 60079-1: 2007-04, IEC 61241-0: 2004, IEC 61241-1: 2004 requirements for use in hazardous areas.

Hazardous Areas Approval KEMA 08ATEX0045/IEC KEM08.0012 for:  
Category II 2 G for Gas protection Ex d IIC T6...T3  
Category II 2 D for Dust protection Ex tD A21 IP67 T90°C...T121°C

#### Directive 89/336/EEC EMC

Immunity specifications: EN 61000-6-2: 2001; EN 61000-4-2 1995; EN 61000-4-3: 1996;  
EN 61000-4-4 1995; EN 61000-4-5 1995; EN 61000-4-6 2003; EN 61000-4-8 1995;  
EN 61000-4-11 1994.

Emissions specification: EN 61000-6-4: 2001; EN55011 1998 Group1 Class A; CISPR 11 1997 Group 1 Class A.

#### Directive 97/23/EC Pressure Equipment

The ST51 Model does not have a pressure bearing housing and is therefore not considered as pressure equipment by itself according to article 1, section 2.1. The Model ST75 is in conformity with the sound engineering practices as defined in the Pressure Equipment Directive 97/23/EC article 3, paragraph 3

Issued at San Marcos, California USA  
August, 2008

 Eric Wible  
2008.09.03  
09:26:40 -0700

Eric Wible, Engineering Manager

Flow/Liquid Level/Temperature Instrumentation  
Visit FLC on the Worldwide Web [www.fluidcomponents.com](http://www.fluidcomponents.com)  
1755 La Costa Meadows Drive, San Marcos, California 92078 USA 760-744-6950 • 800-854-1993 • 760-736-6250  
European Office: Persephonestraat 3-01 5047 TTilburg - The Netherlands - Phone 31-13-5159989 • Fax 31-13-5799036

Doc no. 23EN000019-

## Safety Instructions for the use the ST51/75 flowmeter in Hazardous Areas Approval KEMA 08ATEX0045/IEC KEM08.0012 for:

Category II 2 G for Gas protection Ex d IIC T6...T3

Category II 2 D for Dust protection Ex tD A21 IP67 T90°C...T121°C

The ST51/75 series consist of a sensing element and associated integral or remote mounted electronics mounted in a type "d" flameproof enclosure.

Relation between ambient temperature, process temperature and temperature class is as follows:

Ambient temperature range (Ta):	T6 [85°C] for : -40°C <Ta< + 65°C
Process temperature range (Tp):	T6 [85°C] for : -40°C <Tp< + 65°C T5 [100°C] for : -40°C <Tp< + 100°C T4 [135°C] for : -40°C <Tp< + 135°C T3 [200°C] for : -40°C <Tp< + 200°C

Electrical data: Power supply: 85 to 265 VAC, 50/60 Hz, 12 Watt max; 24 VDC, 12 VA Max

Dansk	Sikkerhedsforskrifter	Italiano	Normative di sicurezza
Deutsch	Sicherheitshinweise	Nederlands	Veiligheidsinstructies
English	Safety instructions	Português	Normas de segurança
Υπ	Υπ δει εις ασφαλειας	Español	Instrucciones de seguridad
Suomi	Turvallisuusohjeet	Svenska	Säkerhetsanvisningar
Français	Consignes de sécurité		

## **DK** Dansk- Sikkerhedsforskrifter

Disse sikkerhedsforskrifter gælder for Fluid Components, ST51/75 EF-typeafprøvningsattest-nr. KEMA 08ATEX0045/IEC KEM08.0012 (attestens nummer på typeskiltet) er egnet til at blive benyttet i eksplosiv atmosfære kategori II 2 GD.

- 1) Ex-anlæg skal principielt opstilles af specialiseret personale.
- 2) ST51/75 skal jordforbindes.
- 3) Klemmerne og elektronikken er monteret i et hus, som er beskyttet af en eksplosionssikker kapsling med følgende noter:
  - Gevindspalten mellem huset og låget er på en sådan måde, at ild ikke kan brede sig inden i det.
  - Ex-„d“ tilslutningshuset er forsynet med et 1/2" NPT og/eller M20x1.5 gevind for montering af en Ex-„d“ kabelindføring, der er atterteret iht. IEC/EN 60079-1
  - Det er vigtigt at sørge for, at forsyningsledningen er uden spænding eller eksplosiv atmosfære ikke er til stede, før låget åbnes og når låget er åbent på „d“ huset (f.eks. ved tilslutning eller servicearbejde).
  - Låget på „d“ huset skal være skruet helt ind, når apparatet er i brug. Det skal sikres ved at dreje en af låseskruerne på låget ud.

## **DA** Deutsch-Sicherheitshinweise

Diese Sicherheitshinweise gelten für die Fluid Components, ST51/75 flowmeter gemäß der EG-Baumusterprüfbescheinigung Nr. KEMA 08ATEX0045/IEC KEM08.0012 (Bescheinigungsnummer auf dem Typschild) der Kategorie II 2 GD.

- 1) Die Errichtung von Ex-Anlagen muss grundsätzlich durch Fachpersonal vorgenommen werden.
- 2) Der ST51/75 muß geerdet werden.
- 3) Die Klemmen und Elektronik sind in einem Gehäuse in der Zündschutzart druckfeste Kapselung („d“) eingebaut.
  - Der Gewindespalt zwischen dem Gehäuse und dem Deckel ist ein zünddurchschlagsicherer Spalt.
  - Das Ex-„d“ Anschlussgehäuse besitzt ein 1/2" NPT und/oder M20x1.5 Gewinde für den Einbau einer nach IEC/EN 60079-1 bescheinigten Ex-„d“ Kabeleinführung.
  - Es ist sicherzustellen, dass vor dem Öffnen und bei geöffnetem Deckel des „d“ Gehäuses (z.B. bei Anschluss oder Service- Arbeiten) entweder die Versorgungsleitung spannungsfrei oder keine explosionsfähige Atmosphäre vorhanden ist.
  - Der Deckel des „d“ Gehäuses muss im Betrieb bis zum Anschlag hineingedreht sein. Er ist durch eine der Deckelarretierungsschrauben zu sichern.

## **GB IRL** English- Safety instructions

These safety instructions are valid for the Fluid Components, ST51/75 flowmeter to the EC type approval certificate no KEMA 08A KEM08.0012 (certificate number on the type label) for use in potentially explosive atmospheres in Category II 2 GD.

- 1) The installation of Ex-instruments must be made by trained personnel.
- 2) The ST51/75 must be grounded.
- 3) The terminals and electronics are installed in a flame proof and pressure-tight housing with following notes:
  - The gap between the housing and cover is an ignition-proof gap.
  - The Ex-“d” housing connection has a 1/2” NPT and/or M20x1.5 cable entry for mounting an Ex-d cable entry certified acc. to IEC/EN 60079-1.
  - Make sure that before opening the cover of the Ex”d” housing, the power supply is disconnected or there is no explosive atmosphere present (e.g. during connection or service work).
  - During normal operation: The cover of the “d” housing must be screwed in completely and locked by tightening one of the cover locking screws.

## **GR** Υπ\_δεί\_εις ασφαλείας

Αυτές οι οδηγίες ασφαλείας ισχύουν για τα Ροόμετρα της Fluid Components τύπου ST51/75 που φέρουν Πιστοποιητικό Εγκρίσεως Ευρωπαϊκής Ένωσης, με αριθμό πιστοποίησης KEMA 08ATEX0045/IEC KEM08.0012 (ο αριθμός πιστοποίησης βρίσκεται πάνω στην ετικέτα τύπου του οργάνου) για χρήση σε εκρηκτικές ατμόσφαιρες της κατηγορίας II 2 GD.

- 1) Η εγκατάσταση των οργάνων με αντεκρηκτική προστασία πρέπει να γίνει από εξειδικευμένο προσωπικό.
- 2) Το όργανο τύπου ST51/75 πρέπει να είναι γειωμένο.
- 3) Τα θερματικά ηλεκτρικών συνδέσεων (κλέμες) και τα ηλεκτρονικά κυκλώματα είναι εγκατεστημένα σε περίβλημα αντεκρηκτικό και αεροστεγές σύμφωνα με τις ακόλουθες παρατηρήσεις:
  - Το κενό ανάμεσα στο περίβλημα και στο κάλυμμα είναι τέτοιο που αποτρέπει την διάδοση σπινθήρα.
  - Το “Ex-d” αντεκρηκτικό περίβλημα, έχει ανοίγματα εισόδου καλωδίου με διάμετρο 1/2” NPT ή/και M20x1.5, κατάλληλα για τοποθέτηση υποδοχής αντεκρηκτικού καλωδίου πιστοποιημένης κατά IEC/EN 60079-1
  - Βεβαιωθείτε ότι πριν το άνοιγμα καλύμματος του του “Ex-d” αντεκρηκτικού περιβλήματος, η τάση τροφοδοσίας είναι αποσυνδεδεμένη ή ότι δεν υφίσταται στη περιοχή εκρηκτική ατμόσφαιρα (π.χ. κατά τη διάρκεια της σύνδεσης ή εργασιών συντήρησης)
  - Κατά τη διάρκεια ομαλής λειτουργίας: Το κάλυμα του “d” καλύμματος αντεκρηκτικού περιβλήματος πρέπει να είναι εντελώς βιδωμένο και ασφαλισμένο, σφίγγοντας μία από τις βίδες ασφαλείας του περιβλήματος.

## **FIN** Suomi - Turvallisuusohjeet

Nämä turvallisuusohjeet koskevat Fluid Components, ST51/75 EY-tyyppitarkastustodistuksen nro. KEMA 08ATEX0045/IEC KEM08.0012 (todistuksen numero näkyy tyyppikilvestä) käytettäessä räjähdysvaarallisissa tiloissa luokassa II 2GD.

- 1) Ex-laitteet on aina asennettava ammattihenkilökunnan toimesta.
- 2) ST51/75 on maadoitettava.
- 3) Syöttöjännitteen kytkemisessä tarvittavat liittimet ja elektroniikka on asennettu koteloon jonka rakenne kestää räjähdyspaineen seuraavin lisäyksin :
  - Kotelon ja kannen välissä on räjähdyspurkausväli.
  - Ex-d liittämät kotelossa on 1/2” NPT ja/tai M20x1.5 kierre IEC/EN 60079-1 mukaisen Ex-d kaapeliläpiviennin asennusta varten
  - Kun “d”-kotelon kansi avataan (esim. liittännän tai huollon yhteydessä), on varmistettava, että joko syöttöjohto on jännitteetön tai ympäristössä ei ole räjähtäviä aineita.
  - “d” -kotelon kansi on kierrettävä aivan kiinni käytön yhteydessä ja on varmistettava kiertämällä yksi kannen lukitusruuveista kiinni.

## **F B L** Consignes de sécurité

Ces consignes de sécurité sont valables pour le modèle ST51/75 de la société Fluid Components (FCI) conforme au certificat d'épreuves de type KEMA 08ATEX0045/IEC KEM08.0012 (numéro du certificat sur l'étiquette signalétique) conçu pour les applications dans lesquelles un matériel de la catégorie II2GD est nécessaire.

- 1) Seul un personnel spécialisé et qualifié est autorisé à installer le matériel Ex.
- 2) Les ST51/75 doivent être reliés à la terre.
- 3) Les boîmes pour le branchement de la tension d'alimentation et l'électronique sont logées dans un boîtier à enveloppe antidéflagrante avec les notes suivantes
  - Le volume entre le boîtier et le couvercle est protégé en cas d'amorçage.
  - Le boîtier de raccordement Ex-d dispose d'un filetage 1/2" NPT et/ou M20x1.5 pour le montage d'un presse-étoupe Ex-d certifié selon la IEC/EN 60079-1.
  - Avant d'ouvrir le couvercle du boîtier « d » et pendant toute la durée où il le restera (pour des travaux de raccordement, d'entretien ou de dépannage par exemple), il faut veiller à ce que la ligne d'alimentation soit hors tension ou à ce qu'il n'y ait pas d'atmosphère explosive.
  - Pendant le fonctionnement de l'appareil, le couvercle du boîtier « d » doit être vissé et serré jusqu'en butée. La bonne fixation du couvercle doit être assurée en serrant une des vis d'arrêt du couvercle.

## **I** Italiano - Normative di sicurezza

Queste normative di sicurezza si riferiscono ai Fluid Components, ST51/75 secondo il certificato CE di prova di omologazione n° KEMA 08ATEX0045/IEC KEM08.0012 (numero del certificato sulla targhetta d'identificazione) sono idonei all'impiego in atmosfere esplosive applicazioni che richiedono apparecchiature elettriche della Categoria II 2 GD.

- 1) L'installazione di sistemi Ex deve essere eseguita esclusivamente da personale specializzato.
- 2) I ST51/75 devono essere collegati a terra.
- 3) I morsetti per il collegamento e l'elettronica sono incorporati in una custodia a prova di esplosione („d“) con le seguenti note:
  - La sicurezza si ottiene grazie ai cosiddetti „interstizi sperimentali massimi“, attraverso i quali una eventuale accensione all'interno della custodia non può propagarsi all'esterno oraggiungere altre parti dell'impianto.
  - La scatola di collegamento Ex-d ha una filettatura 3/4" e/o 1" NPT per il montaggio di un passacavo omologato Ex-d secondo IEC/EN 60079-1.
  - Prima di aprire il coperchio della custodia „d“ (per es. durante operazioni di collegamento o di manutenzione) accertarsi che l'apparecchio sia disinserito o che non si trovi in presenza di atmosfere esplosive.
  - Avvitare il coperchio della custodia „d“ fino all'arresto. Per impedire lo svitamento del coperchio è possibile allentare una delle 2 viti esagonali poste sul corpo della custodia, incastrandola nella sagoma del coperchio.

## **NL B** Nederlands - Veiligheidsinstructies

Deze veiligheidsinstructies gelden voor de Fluid Components, ST51/75 overeenkomstig de EG-typeverklaring nr. KEMA 08ATEX0045/IEC KEM08.0012 (nummer van de verklaring op het typeplaatje) voor gebruik in een explosieve atmosfeer volgens Categorie II 2GD.

- 1) Installatie van Ex-instrumenten dient altijd te geschieden door geschoold personeel.
  - 2) De ST51/75 moet geaard worden.
  - 3) De aansluitklemmen en de electronika zijn ingebouwd in een drukvaste behuizing met de volgende opmerkingen:
    - De schroefdraadspleet tussen de behuizing en de deksel is een ontstekingsdoorslagveilige spleet.
    - De Ex-d aansluitbehuizing heeft een 1/2" of een M20x1.5 schroefdraad voor aansluiting van een volgens IEC/EN 60079-1 goedgekeurde Ex- 'd' kabelinvoer.
    - Er moet worden veilig gesteld dat vóór het openen bij een geopende deksel van de 'd' behuizing (bijv. bij aansluit- of servicewerkzaamheden) hetzij de voedingsleiding spanningsvrij is, hetzij geen explosieve atmosfeer aanwezig is.
    - De deksel van de 'd' behuizing moet tijdens bedrijf tot aan de aanslag erin geschroefd zijn.
- Hij moet door het eruit draaien van een van de dekselborgschroeven worden geborgd.

## **P** Português - Normas de segurança

Estas normas de segurança são válidas para os Fluid Components, ST51/75 conforme o certificado de teste de modelo N.º KEMA 08ATEX0045/IEC KEM08.0012 (número do certificado na plaqueta com os dados do equipamento)

são apropriados para utilização em atmosferas explosivas categoria II 2 GD.

- 1) A instalação de equipamentos em zonas sujeitas a explosão deve, por princípio, ser executada por técnicos qualificados.
- 2) Os ST51/75 Flexmaster precisam ser ligados à terra.
- 3) Os terminais e a electrónica para a conexão da tensão de alimentação estão instalados num envólucro com protecção contra ignição á prova de sobrepressão com as seguintes notas
  - A fenda entre o envólucro e a tampa deve ser á prova de passagem de centelha.
  - O envólucro de conexão Ex-"d" possui uma rosca 1/2" NPT e/ou M20x1.5 para a entrada de cabos Ex-"d" certificado conforme a norma IEC/EN 60079-1.
  - Deve-se assegurar que, antes de abrir a tampa do armário „d" ( por exemplo, ao efectuar a conexão ou durante trabalhos de manutenção), o cabo de alimentação esteja sem tensão ou que a atmosfera não seja explosiva.
  - Durante a operação, a tampa do envólucro „d" deve estar aparafusada até o encosto. A tampa deve ser bloqueada, por um dos parafusos de fixação.

## **E** Español - Instrucciones de seguridad

Estas indicaciones de seguridad son de aplicación para el modelo ST51/75 de Fluid Components, según la certificación CE de modelo N° KEMA 08ATEX0045/IEC KEM08.0012 para aplicaciones en atmósferas potencialmente explosivas según la categoría II 2 GD (el número de certificación se indica sobre la placa informativa del equipo).

- 1) La instalación de equipos Ex tiene que ser realizada por personal especializado.
- 2) Los ST51/75 tienen que ser conectados a tierra.
- 3) Los bomes de conexión y la unidad electrónica están montados dentro de una caja con protección antideflagrante y resistente a presión, considerándose los siguientes puntos:
  - La holgura entre la rosca de la tapa y la propia de la caja está diseñada a prueba contra ignición.
  - La caja tiene conexiones eléctricas para entrada de cables con rosca 1/2" NPTy/o M20x1.5, donde deberán conectarse prensaestopas certificados Exd según IEC/EN60079-1.
  - Antes de la apertura de la tapa de la caja "Exd" (p. ej. durante los trabajos de conexionado o de puesta en marcha) hay que asegurar que el equipo se halle sin tensión o que no exista presencia de atmósfera explosiva.
  - Durante el funcionamiento normal: la tapa de la caja antideflagrante tiene que estar cerrada, roscada hasta el tope, debiéndose asegurar apretando los tornillos de bioqueo.

## **S** Svenska - Säkerhetsanvisningar

Säkerhetsanvisningarna gäller för Fluid Components, Flödesmätare typ ST51/75 enligt EG-typkontrollintyg nr KEMA 08ATEX0045/IEC KEM08.0012 (intygsnumret återfinns på typskylten) är lämpad för användning i explosiv gasblandning i kategori II 2 GD.

- 1) Installation av Ex- klassade instrument måste alltid utföras av fackpersonal.
- 2) ST51/75 måste jordas.
- 3) Anslutningsklämmorna och elektroniken är inbyggda i en explosions och trycktät kapsling med följande kommentar:
  - Spalten mellan kapslingen och lockets gänga är flamsäker.
  - Ex-d kapslingen har en 1/2" NPT och / eller M20x1.5 gänga för montering av en IEC/EN 60079-1 typkontrollerad Ex- „d" kabel förskruvning
  - När Ex- „d"-kapslingens lock är öppet (t.ex. vid inkoppling - eller servicearbeten) ska man se till att enheten är spänningslös eller att ingen explosiv gasblandning förekommer.
  - Under drift måste Ex - d"-kapslingens lock vara iskruvad till anslaget. För att säkra locket skruvar man i en av lockets insex låsskruvar .

**INTENTIONALLY LEFT BLANK**

## Appendix B - List Commands

COMMAND MNEMONIC	COMMAND FUNCTION	COMMAND DESCRIPTION
A	R	AvgDelta_r, AvgRef
B	R	Delta_r, Ref_r
C	R	Tcdelta_r, Ref_r
D	R	Diagnostics
F	R/W	Kfactors
G	R/W	Clear FlashEE, Boxcar Count, ADC to Ohms Cal
K	R/W	Cal Parameters
L	R/W	Output Cal
N	W	Warm Restart
R	W	Factory Restore
S	R/W	Totalizer Menu On/Off
T	R	Normal Mode
V	R/W	Output Config
W	R/W	Totalizer
Y	W	Command Line Interface
Z	W	Flow units, Pipe Size, and LCD Scaling

Table 5. ST75/ST75V List of Single Letter Commands

COMMAND MNEMONIC	COMMAND FUNCTION	COMMAND DESCRIPTION	DATA TYPE
BK	R/W	Break Point	Float
BM	R/W	Boxcar Filter Max	Integer
CM	R/W	Cminflow	Float
CR	R/W	Calibration Ref	Float
CX	R/W	Cmaxflow	Float
C1[1-5]	R/W	Coefficients set1	Float
C2[1-5]	R/W	Coefficients set2	Float
DI	R	Diagnostics	Null
DM	R/W	DeltaR Minimum	Float
DN	R/W	Density	Float
DR	R	Delta R	Float
DX	R/W	DeltaR Maximum	Float
DS	R/W	DeltaR Slope	Float
DF	R/W	DeltaR Offset	Float
EU	R/W	Engineering Units	Integer
FF	R/W	Flow Factor	Float
FP	R/W	Fix Point Flag	Integer
F0	R/W	Pulse Out State0	Integer
F1	R/W	Pulse Out State1	Integer
HR	R/W	Tot Dump Hours Cntr	Integer
IF	R/W	I Factor	Float

Table 6. ST75/ST75V List of CLI Commands

**Table 6. ST75/ST75V List of CLI Commands, Cont.**

COMMAND MNEMONIC	COMMAND FUNCTION	COMMAND DESCRIPTION	DATA TYPE
K[1-4]	R/W	K Factors	Float
L0	R/W	Line Size0	Float
L1	R/W	Line Size1	Float
MN	R/W	Minflow	Float
MX	R/W	Maxflow	Float
OM	R/W	Outmode	Integer
PF	R/W	Pulse Factor	Float
PL	R/W	Pulse Out	Integer
PS	R/W	Pulse Sample Period	Float
PW	R/W	Pulse Width	Float
P0	R/W	Switch Point0	Integer
P1	R/W	Switch Point1	Integer
RO	R/W	RollOver Cntr	Long
RR	R	Reference R	Float
RS	R/W	RefR Slope	Float
RF	R/W	RefR Offset	Float
SF	R	SFPS Flow	Float
SN	R/W	Serial Number	String (16 chars max.)
SO	R/W	Shop Order Number	String (16 chars max.)
S0	R/W	SpanDAC0 for 4-20mA #1	Integer
S3	R/W	SpanDAC1 for 4-20mA #2	Integer
S2	W	Save FACTORY	N/A
TC	R	TCdeltar	Float
TD	R/W	Tcslp	Float
TF	R/W	Totalizer OFF/ON Flag	Integer
TM	R/W	Cmintemp	Float
TP	R/W	Totalizer Temperature Flag	Integer
TT	R/W	Totalizer Value	Float
TX	R/W	Cmaxtemp	Float
TZ	R	Temperature	Float
T0	R/W	Tcslp0	Float
T2	R/W	Tcslp2	Float
T3	R/W	TSpanDAC0 for 4-20mA #1	Integer
T7	R/W	TSpanDAC1 for 4-20mA #2	Integer
T5	R/W	TZeroDAC0 for 4-20mA #1	Integer
T8	R/W	TZeroDAC1 for 4-20mA #2	Integer
UF	R	User Flow	Float
UK	R	User FlowK	Float
UN	R/W	User Name	String (16 chars max.)
VN	R	Version Number	String (16 chars max.)
XX	R/W	Test Flow Rate (SFPS)	Float
XY	W	Delete Test Flow Rate	Float
Z0	R/W	ZeroDAC0 for 4-20mA #1	Integer
Z2	R/W	ZeroDAC1 for 4-20mA #2	Integer

Command Line Password: 357



NOTE: When invoking a Write Function, there must be a space separating the Command characters and the data value. All Read and Write Functions are completed with a <CR>. To exit CLI, press <CR> following the last Command <CR>.

Examples:	RBK<CR>	(Read Breakpoint)
	WBK 2222<CR>	(Write Breakpoint 2222)
	RC11<CR>	(Read Coefficient C1,1)
	WC11 -234.567<CR>	(Write Coefficient C1,1, -234.567)
	<CR>	(Leave Command Line Mode)

**INTENTIONALLY LEFT BLANK**

# Appendix C - Drawings

4
3
2
1

**NOTICE OF PROPRIETARY RIGHTS**

This document contains confidential technical data, including trade secrets and proprietary information which are the property of Fluid Components Intl (FCI). Disclosure of this data to you is expressly conditioned upon your consent that its use is limited to use within your company only (and does not include manufacture or processing uses). Any other use is strictly prohibited without the prior written consent of FCI.

REV	DESCRIPTION	DATE
1	MAJOR (SEE DCN)	9/9/08

**TUBE TEE CONFIGURATION**

CONFIG	DIM A TUBE SIZE	DIM B TOP TO FLOW CL	DIM C FLOW CL TO BOTTOM	DIM D TEE LENGTH
ST75-EX2222	1/4 INCH TUBING	5.7 MAX [144.8]	.33 [8.38]	2.34 [59.44]
ST75-EX2223	1/2 INCH TUBING	5.9 MAX [149.8]	.53 [13.46]	2.84 [72.14]
ST75-EX2224	1 INCH TUBING	7.8 MAX [198.1]	.87 [22.10]	3.88 [98.54]

**SPECIFICATIONS:**

CUSTOMER: \_\_\_\_\_

PURCHASE ORDER NO.: \_\_\_\_\_

CUSTOMER ORDER NO.: \_\_\_\_\_

WETTED SURFACE MATERIAL: \_\_\_\_\_

FERRULE TYPE: \_\_\_\_\_

U LENGTH: \_\_\_\_\_

SERIAL NO.(S): \_\_\_\_\_

TAG NO.(S): \_\_\_\_\_

6. PROCESS PRESSURE: 600 PSIG MAX.

5. SEE INSTRUMENT MANUAL FOR ADDITIONAL INFORMATION AND INSTRUCTION.

4. ALL ORIENTATION AND/OR MOUNTING REFERENCES ARE INDICATED FROM TERMINAL ENCLOSURE END OF SENSING ELEMENT.

3. FOR ELECTRICAL OPTIONS, CONNECTIONS AND TESTS. SEE APPLICABLE WIRING DIAGRAM.

2. DIMENSIONS IN BRACKETS [ ] ARE IN MILLIMETERS.

1. THIS DRAWING IS A REFERENCE DOCUMENT ONLY.

NOTES: UNLESS OTHERWISE SPECIFIED

**OUTLINE/INSTALLATION DRAWING**

4
3
2
1

**NOTICE OF PROPRIETARY RIGHTS**

This document contains confidential technical data, including trade secrets and proprietary information which are the property of Fluid Components Intl (FCI). Disclosure of this data to you is expressly conditioned upon your consent that its use is limited to use within your company only (and does not include manufacture or processing uses). Any other use is strictly prohibited without the prior written consent of FCI.

REV	DESCRIPTION	DATE
1	MAJOR (SEE DCN)	9/9/08

**PIPE TEE CONFIGURATION**

CONFIG	DIM A PIPE SIZE	DIM B TOP TO FLOW CL	DIM C FLOW CL TO BOTTOM	DIM D TEE LENGTH
ST75-EX2222	1/4 INCH PIPE	5.8 MAX [148.3]	.50 [12.70]	1.54 [39.12]
ST75-EX2223	1/2 INCH PIPE	6.5 MAX [165.1]	.50 [12.70]	2.28 [58.03]
ST75-EX2224	3/4 INCH PIPE	7.0 MAX [177.8]	.68 [17.27]	2.56 [65.02]
ST75-EX2225	1 INCH PIPE	7.8 MAX [198.1]	.80 [20.32]	2.88 [73.15]
ST75-EX2226	1 1/2 INCH PIPE	8.0 MAX [203.2]	1.17 [29.72]	3.83 [97.25]
ST75-EX2227	2 INCH PIPE	8.0 MAX [203.2]	1.22 [31.00]	4.58 [116.40]

**SPECIFICATIONS:**

CUSTOMER: \_\_\_\_\_

PURCHASE ORDER NO.: \_\_\_\_\_

CUSTOMER ORDER NO.: \_\_\_\_\_

WETTED SURFACE MATERIAL: \_\_\_\_\_

U LENGTH: \_\_\_\_\_

SERIAL NO.(S): \_\_\_\_\_

TAG NO.(S): \_\_\_\_\_

6. PROCESS PRESSURE: 240 PSIG MAX.

5. SEE INSTRUMENT MANUAL FOR ADDITIONAL INFORMATION AND INSTRUCTION.

4. ALL ORIENTATION AND/OR MOUNTING REFERENCES ARE INDICATED FROM TERMINAL ENCLOSURE END OF SENSING ELEMENT.

3. FOR ELECTRICAL OPTIONS, CONNECTIONS AND TESTS. SEE APPLICABLE WIRING DIAGRAM.

2. DIMENSIONS IN BRACKETS [ ] ARE IN MILLIMETERS.

1. THIS DRAWING IS A REFERENCE DOCUMENT ONLY.

NOTES: UNLESS OTHERWISE SPECIFIED

**OUTLINE/INSTALLATION DRAWING**



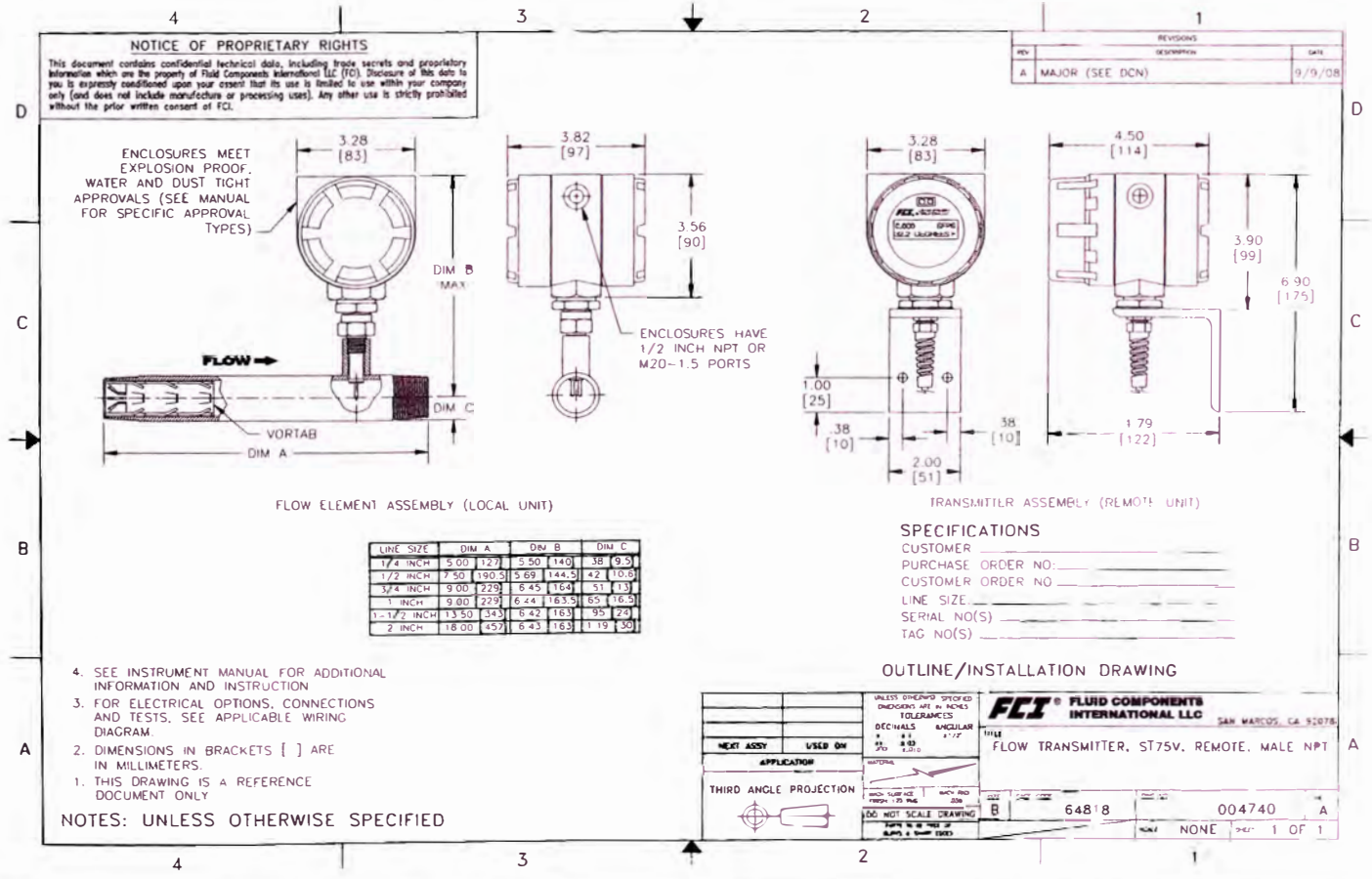
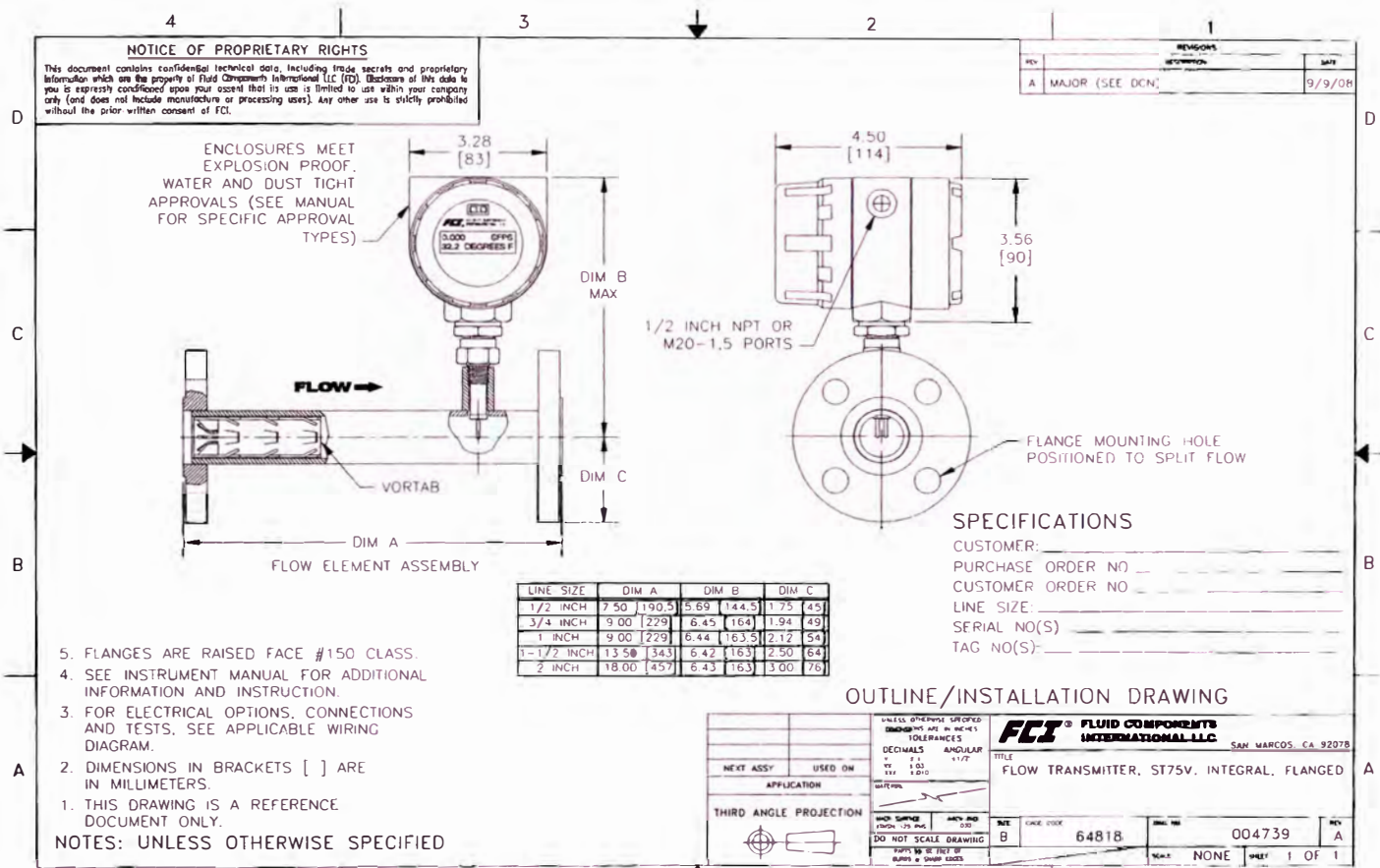









# Appendix D - Customer Service

## **Customer Service/ Technical Support**

FCI provides full in-house technical support. Additional technical representation is also provided by FCI field representatives. Before contacting a field or in-house representative, please perform the troubleshooting techniques outlined in this document.

### **By Mail**

Fluid Components International LLC  
1755 La Costa Meadows Dr.  
San Marcos, CA 92078-5115 USA  
Attn: Customer Service Department

### **By Phone**

Contact the area FCI regional representative. If a field representative is unable to be contacted or if a situation is unable to be resolved, contact the FCI Customer Service Department toll free at 1 (800) 854-1993.

### **By Fax**

To describe problems in a graphical or pictorial manner, send a fax including a phone or fax number to the regional representative. Again, FCI is available by facsimile if all possibilities have been exhausted with the authorized factory representative. Our Fax number is 1 (760) 736-6250; it is available 7 days a week, 24 hours a day.

### **By E-Mail**

FCI Customer Service can be contacted by e-mail at: [techsupport@fluidcomponents.com](mailto:techsupport@fluidcomponents.com). Describe the problem in detail making sure a telephone number and best time to be contacted is stated in the e-mail.

### **International Support**

For product information or product support outside the contiguous United States, Alaska, or Hawaii, contact your country's FCI International Representative or the one nearest to you.

### **After Hours Support**

For product information visit FCI's Worldwide Web at [www.fluidcomponents.com](http://www.fluidcomponents.com). For product support call 1 (800) 854-1993 and follow the prerecorded instructions.

### **Point of Contact**

The point of contact for service, or return of equipment to FCI is your authorized FCI sales/service office. To locate the office nearest you, please go to [www.fluidcomponents.com](http://www.fluidcomponents.com).

**Warranty Repairs or Returns**

FCI prepays ground transportation charges for return of freight to the customer's door. FCI reserves the right to return equipment by the carrier of our choice.

International freight, handling charges, duty/entry fees for return of equipment are paid by the customer.

**Non-Warranty Repairs or Returns**

FCI returns repaired equipment to the customer either collect or prepaid and adds freight charges to the customer invoice.

**Return to Stock Equipment**

The customer is responsible for all shipping and freight charges for equipment that is returned to FCI stock from the customer site. These items will not be credited to customer's account until either all freight charges are cleared or until the customer agrees to have any freight costs incurred by FCI deducted, along with applicable return to stock charges, from the credit invoice.

(Exceptions are made for duplicate shipments made by FCI.)

If any repair or return equipment is received at FCI, freight collect, without prior factory consent, FCI bills the sender for these charges.

**Field Service Procedures**

Contact an FCI field representative to request field service.

A field service technician is dispatched to the site from either the FCI factory or one of the FCI representative offices. After the work is complete, the technician completes a preliminary field service report at the customer site and leaves a copy with the customer.

Following the service call, the technician completes a formal, detailed service report. The formal report is mailed to the customer within five days of the technician's return to the factory or office.

**Field Service Rates**

All field service calls are billed at the prevailing rates as listed in the FCI Price Book unless specifically excepted by the FCI Customer Service Manager. FCI reserves the right to bill for travel times at FCI's discretion.

Customers are charged for shipping costs related to the transfer of equipment to and from the job site. They are also invoiced for field service work and travel expenses by FCI's Accounting Department.



## Fax Cover Sheet

Company: \_\_\_\_\_ Date: \_\_\_\_\_  
 Attention: \_\_\_\_\_ Dept: \_\_\_\_\_  
 Fax No: \_\_\_\_\_ Direct Phone: \_\_\_\_\_  
 From: \_\_\_\_\_ No. of Pages: \_\_\_\_\_

To expedite repairs the following Return Authorization Request form **must be completed and faxed back to FCI before** a Return Authorization Number will be issued. The Decontamination Statement **must be signed** and Applicable MSDS Sheets **must be included with the shipment**. FCI will either fax or telephone you with the Return Authorization Number upon receipt of the completed form.

### Packing Procedures

- Electronics** should be wrapped in an **anti-static** or **static-resistant** bag (FCI can provide), then wrapped in protective bubble wrap and surrounded with appropriate dunnage\* in a box. Instruments weighing up to **50 lbs.**, should be wrapped in protective wrap and surrounded with appropriate dunnage\* in a box. Instruments weighing **more than 50 lbs.**, or **extending more than four feet** should be secured in wooden crates by bolting the assemblies in place.
- The sensor element must be protected** with tubing or other sturdy wrapping or, when applicable, retracted completely and secured into the Packing Gland Assembly. FCI will supply suitable probe protectors at your request (see diagram - right).
- FCI can supply crates at a nominal fee.
- No more than **four (4)** small units packaged in each carton.
- Packages weighing in excess of **70 lbs.**, or **with the combined length and girth of more than 138"** cannot be shipped via UPS and should be shipped via carriers who specialize in the transport of industrialized instrumentation.
- FCI will not be held liable for damage caused during shipping.
- To ensure immediate processing **mark** the RA number on the outside of the box. Items without an RA number marked on the box or crate may be delayed.
- Freight **Must be "PrePaid"** to FCI receiving door.



Anti-Static Bag

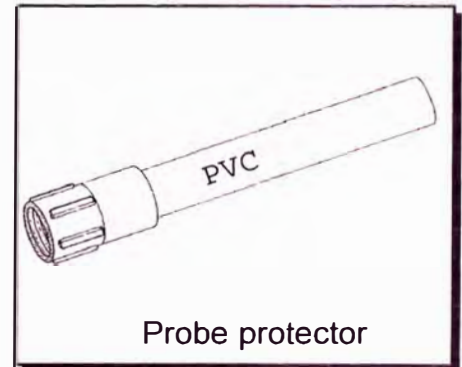

Probe protector

Factory Return Shipping Address: **Fluid Components International LLC**  
**1755 La Costa Meadows Drive**  
**San Marcos, CA 92078-5115**  
**Attn: Repair Department,**  
**RA # \_\_\_\_\_**

\* Appropriate dunnage as defined by UPS, will protect package contents from a drop of 3 feet.

This message is intended for the use of the individual or entity to whom it is addressed and may contain proprietary data or confidential business or financial information that can only be used, copied, or disclosed as authorized by Fluid Components.

Visit FCI on the Worldwide Web: [www.fluidcomponents.com](http://www.fluidcomponents.com)

1755 La Costa Meadows Drive, San Marcos, California 92078 USA ‡ Phone: 760-744-6950 ‡ 800-854-1993 ‡ Fax: 760-736-6250



1755 La Costa Meadows Drive, San Marcos, CA 92078-5115 USA  
760-744-6950 / 800-854-1993 / Fax: 760-736-6250

Web Site: www.fluidcomponents.com / E-mail: techsupport@fluidcomponents.com

RA # \_\_\_\_\_

### Return Authorization Request

**1. Return Customer Information**

Returning Company's Name: \_\_\_\_\_ Fax # \_\_\_\_\_

Return Contact Name: \_\_\_\_\_ Phone # \_\_\_\_\_

Email Address: \_\_\_\_\_

**2. Return Address**

Bill To: \_\_\_\_\_ Ship To: \_\_\_\_\_

\_\_\_\_\_  
\_\_\_\_\_  
\_\_\_\_\_

**3. Return Product Information**

Model No: \_\_\_\_\_ Serial No(s): \_\_\_\_\_

Failure Symptoms (Detailed Description Required): \_\_\_\_\_

\_\_\_\_\_  
What Trouble Shooting Was Done Via Phone or Field Visit by FCI: \_\_\_\_\_

FCI Factory Technical Service Contact: \_\_\_\_\_

**4. Reason For Return**

Sensor Element     Electronics     As Found Testing     Credit

Recalibrate (Old Data)     Recalibrate (New Data)     Other

(Note: A new Application Data Sheet (ADS) must be submitted for all recalibrations and re-certifications)

**5. Payment Via**

Faxed Purchase Order       

(Note: A priced quotation is provided for all Non-Warranty repairs after equipment has been evaluated.

All Non-Warranty repairs are subject to a minimum evaluation charge)

Sensor Element Protector Requested     Electronics Anti-Static Bag Requested

**Decontamination Information !      This Section Must Be Completed !**

Exposure to hazardous materials is regulated by Federal, State (California), County and City laws and regulations. These laws provide FCI's employees with the "Right to Know" the hazardous or toxic materials or substances in which they may come in contact while handling returned products. Consequently, our employees must have access to data regarding the hazardous or toxic materials or substances which the equipment has been exposed to in your process(es). Accordingly, prior to returning your instrument for evaluation/repair, please read then sign the certification below and thoroughly comply with the applicable instructions.

I certify that the returned item(s) has(have) been thoroughly and completely cleaned. If the returned item(s) has(have) been exposed to hazardous or toxic materials or substances, the undersigned attests that the attached Material Safety Data Sheet(s) (MSDS) which cover said materials or substances are complete and accompany the returned item(s). Furthermore, I understand that this Certificate, or providing a MSDS, shall not waive our responsibility to provide a neutralized, decontaminated, and clean product for evaluation/repair to FCI. Cleanliness of a returned item or the acceptability of the MSDS shall be at the sole discretion of FCI. Any item returned which does not comply with these instructions shall be returned to your location Freight Collect and at your risk.

Process Flow Media \_\_\_\_\_

Authorized Signature \_\_\_\_\_ Date \_\_\_\_\_

## Instrument Warranty

Goods furnished by the Seller are to be within the limits and of the sizes published by the Seller and subject to the Seller's standard tolerances for variations. All items made by the Seller are inspected before shipment, and should any of said items prove defective due to faults in manufacture or performance under Seller approved applications, or fail to meet the written specifications accepted by the Seller, they will be replaced or repaired by Seller at no charge to Buyer provided return or notice of rejection of such material is made within a reasonable period but in no event longer than one (1) year for non-calibration defects and one (1) year for calibration defects from date of shipment to Buyer, and provided further, that an examination by Seller discloses to Seller's reasonable satisfaction that the defect is covered by this warranty and that the Buyer has not returned the equipment in a damaged condition due to Buyer's or Buyer's employees', agents', or representatives' negligence and Buyer has not tampered, modified, redesigned, misapplied, abused, or misused the goods to cause the goods to fail. In addition, this warranty shall not cover damage caused by Buyer's exposure of the goods to corrosive or abrasive environments. Moreover, Seller shall in no event be responsible for (1) the cost or repair of any work done by Buyer on material furnished hereunder (unless specifically authorized in writing in each instance by Seller), (2) the cost or repair of any modifications added by a Distributor or a third party, (3) any consequential or incidental damages, losses, or expenses in connection with or by reason of the use of or inability to use goods purchased for any purpose, and Seller's liability shall be specifically limited to free replacement, or refund of the purchase price, at Seller's option, provided return or rejection of the goods is made consistent with this paragraph, and the Seller shall in no event be liable for transportation, installation, adjustment, loss of good will or profits, or other expenses which may arise in connection with such returned goods, or (4) the design of products or their suitability for the purpose for which they are intended or used. Should the Buyer receive defective goods as defined by this paragraph, the Buyer shall notify the Seller immediately, stating full particulars in support of his claim, and should the Seller agree to a return of the goods, the Buyer shall follow Seller's packaging and transportation directions explicitly. In no case are the goods to be returned without first obtaining a return authorization from the Seller. Any repair or replacement shall be at Seller's factory, unless otherwise directed, and shall be returned to Seller transportation prepaid by Buyer. If the returned goods shall prove defective under this clause they will be replaced or repaired by Seller at no charge to Buyer provided the return or rejection of such material is made within a reasonable period, but in no event longer than (1) year from the date of shipment of the returned goods or the unexpired terms of the original warranty period whichever is later. If the goods prove to be defective under this paragraph, the Buyer shall remove the goods immediately from the process and prepare the goods for shipment to Seller. Continued use or operation of defective goods is not warranted by Seller and damage occurring due to continued use or operation shall be for Buyer's account. Any description of the goods contained in this offer is for the sole purpose of identifying them, and any such description is not part of the basis of the bargain, and does not constitute a warranty that the goods will conform to that description. The use of any sample or model in connection with this offer is for illustrative purposes only, is not part of the basis of the bargain, and is not to be construed as a warranty that the goods will conform to the sample or model. No affirmation of that fact or promise made by the Seller, whether or not in this offer, will constitute a warranty that the goods will conform to the affirmation or promise. THIS WARRANTY IS EXPRESSLY IN LIEU OF ANY AND ALL OTHER EXPRESS OR IMPLIED WARRANTIES WITH RESPECT TO THE GOODS OR THEIR INSTALLATION, USE, OPERATION, REPLACEMENT OR REPAIR, INCLUDING ANY IMPLIED WARRANTY OF MERCHANTABILITY OR FITNESS OF PURPOSE; AND THE GOODS ARE BEING PURCHASED BY BUYER "AS IS". SELLER WILL NOT BE LIABLE BY VIRTUE OF THIS WARRANTY OR OTHERWISE FOR ANY SPECIAL, INCIDENTAL OR CONSEQUENTIAL LOSS OR DAMAGE RESULTING FROM THE USE OR LOSS OF USE OF THE GOODS.





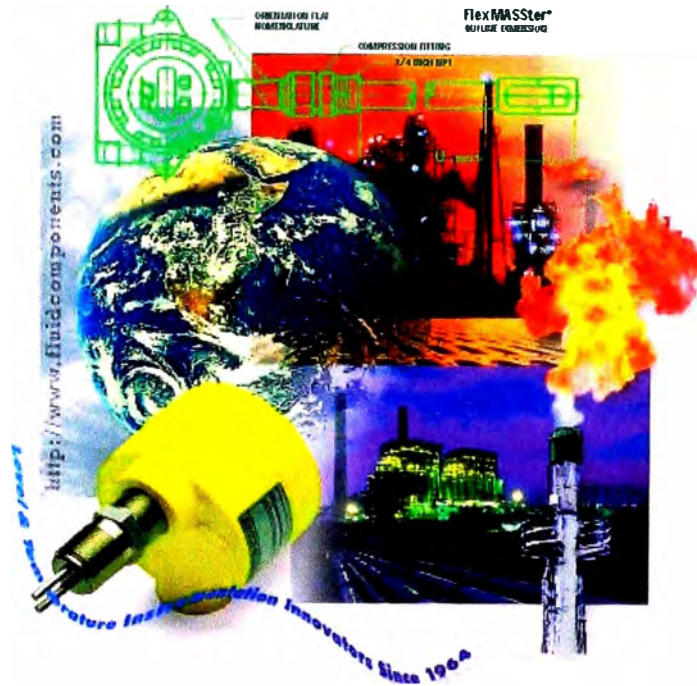

FCI's Complete Customer Commitment. Worldwide  
ISO 9001:2000 and AS9100 Certified

### Notice of Proprietary Rights

This document contains confidential technical data, including trade secrets and proprietary information which is the property of Fluid Components International LLC (FCI). Disclosure of this data to you is expressly conditioned upon your assent that its use is limited to use within your company only (and does not include manufacture or processing uses). Any other use is strictly prohibited without the prior written consent of FCI.

Visit FCI on the Worldwide Web: [www.fluidcomponents.com](http://www.fluidcomponents.com)

1755 La Costa Meadows Drive, San Marcos, California 92078 USA - 760-744-6950 - 800-854-1993 - Fax 760-736-6250



# ST75V Mass Flow Meter

with Vortab® Flow Conditioners



**Precision Mass Flow Meters Compatible with Line Sizes from 1/4" to 2" [6 to 51mm] for Industrial and Commercial Process Gases**

For installations with inadequate straight-run or obstructed flows that prevent a fully developed profile for accurate flow measurement with the standard S175, the Model S175"V" provides the solution. FCI's Model S175V includes all of the features and functionality of the S175 plus built-in Vortab flow conditioning. Vortab flow conditioners are the flow conditioning technology proven and recommended by flow measurement experts to eliminate both swirl and velocity profile distortions to ensure accurate flow measurement.

Vortab flow conditioners also are the lowest pressure loss solution of all flow conditioning techniques. FCI is the exclusive provider of Vortab flow conditioners for use with thermal mass flow meters such as the S175V.

In applications with limited space for pipe straight-run or when obstructors such as valves, bends, couplings or any other disturber which alters the flow profile are present, the S175V is the solution to ensure the highest accuracy and repeatability.

## ST75V Specifications

**Process Connections:** Choice of Female NPT, Male NPT, ANSI flanges, DIN flanges

**Media Compatibility:** Air, compressed air, nitrogen, oxygen, argon, CO<sub>2</sub>, ozone, other inert gases, natural gas and other hydrocarbon gases, hydrogen.

**Accuracy:** ±1% of reading, ±0.5% full scale

**Repeatability:** ±0.5%

**Temperature Compensation:**

Standard: 40°F to 100°F [4°C to 38°C]

Optional: 0°F to 250°F [-18°C to 121°C]

**Turndown Ratio:** 10:1 to 100:1

**Agency Approvals:**

FM/CSA: Class 1, Div. 1, Groups B,C,D; Class 1, Div. 2, Groups A-D

ATEX/IECEX: Zone 1, II 2 G Ex d IIC T6 ..T3; II 2 D Ex td A21, IP67 T90° .. T300°

**Element Materials of Construction:** All-welded 316 Stainless Steel with Hastelloy-C thermowells.

**Enclosure:** NEMA 4X [IP67], aluminum, dual conduit ports with either 1/2 inch NPT or M20x1.5 entries. Epoxy coated.

**Output Signal:**

Standard: (2) 4-20mA, user assignable to flow rate and/or temperature

(1) 0-1000 Hz pulse for total flow

**Maximum Operating Pressure:** 240 psi [16.5 bar(g)]

**Input Power:**

DC: 18 Vdc to 36 Vdc (6 Watts maximum)

AC: 85 Vdc to 265 Vac 85 to 265 Vac (12 Watts maximum) (CE approval for 100 Vac to 240 Vac)

**Operating Temperature Range:** 0°F to 140°F [-18°C to 60°C]

**Digital Display (Optional):** Two-line x 16 characters LCD. Displays measured value and engineering units. Top line assigned to flow rate. Second line is user assignable to temperature reading, as flow totalizer or alternating. Display can be rotated in 90° increments for optimum viewing orientation.

## ST75V Specifications

### Female NPT

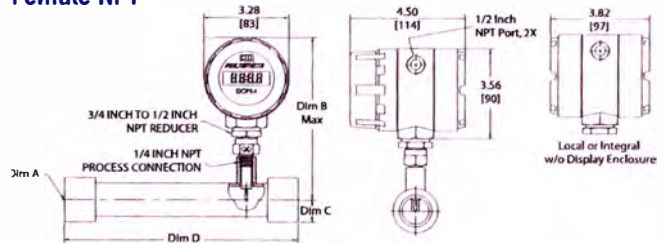

1. Dimensions are in INCHES; brackets [ ] are in MILLIMETERS

Female NPT Configuration				
Configuration	DIM A Pipe Size	DIM B Top to Flow CL	DIM C Flow CL to Bottom	DIM D VMR Length
ST75V-XXXCE	1/4"	5.50 [140]	0.38 [9.5]	5.00 [127]
ST75V-XXXEE	1/2"	5.69 [144.5]	0.57 [14]	7.50 [190.5]
ST75V-XXXFE	3/4"	6.45 [164]	0.69 [17.5]	9.00 [229]
ST75V-XXXGE	1"	6.44 [163.5]	0.88 [22]	9.00 [229]
ST75V-XXXHE	1 1/2"	6.42 [163]	1.25 [32]	13.50 [343]
ST75V-XXXJE	2"	6.43 [163]	1.50 [38]	18.00 [457]

### Male NPT

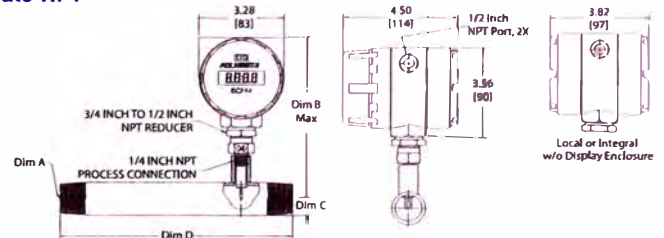

1. Dimensions are in INCHES; brackets [ ] are in MILLIMETERS.

Male NPT Configuration				
Configuration	DIM A Pipe Size	DIM B Top to Flow CL	DIM C Flow CL to Bottom	DIM D Tee Length
ST75V-XXXCN	1/4"	5.50 [140]	0.38 [9.5]	5.00 [127]
ST75V-XXXEN	1/2"	5.69 [144.5]	0.42 [10.6]	7.50 [190.5]
ST75V-XXXFN	3/4"	6.45 [164]	0.51 [13]	9.00 [229]
ST75V-XXXGN	1"	6.44 [163.5]	0.65 [16.5]	9.00 [229]
ST75V-XXXHN	1 1/2"	6.42 [163]	.95 [24]	13.50 [343]
ST75V-XXXJN	2"	6.43 [163]	1.19 [30]	18.00 [457]

### Flanged

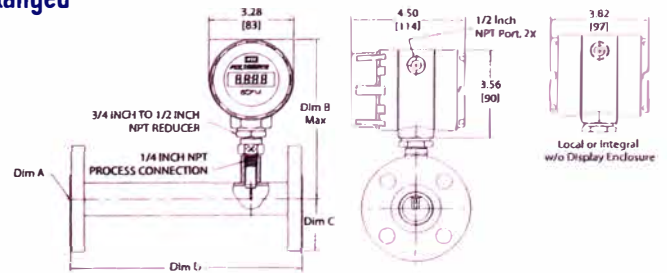

1. Dimensions are in INCHES; brackets [ ] are in MILLIMETERS  
2. Flanges are 150# Class

Flanged Configuration				
Configuration	DIM A Pipe Size	DIM B Top to Flow CL	DIM C Flow CL to Bottom	DIM D Tee Length
ST75V-XXXCF	1/4"	n/a	n/a	n/a
ST75V-XXXEF	1/2"	5.69 [144.5]	1.75 [45]	7.50 [190.5]
ST75V-XXXFF	3/4"	6.45 [164]	1.94 [49]	9.00 [229]
ST75V-XXXGF	1"	6.44 [163.5]	2.12 [54]	9.00 [229]
ST75V-XXXHF	1 1/2"	6.42 [163]	2.50 [64]	13.50 [343]
ST75V-XXXJF	2"	6.43 [163]	3.00 [76]	18.00 [457]

# ORDERING GUIDE: ST75V Mass Flow Meter with Vortab® Flow Conditioners

Block No.	1	2	3	4	5	6	7	8	9	10
Model ST75V-										

Base Unit, Enclosure Style (Block 1) <i>Enclosures: All Aluminum, NEMA 4X/1757 rated, epoxy coated</i>	Code
Panel Mount, Integral Transmitter, with two 1/2" FNPT cable entries	1
Panel Mount, Integral Transmitter with Local Digital Display, with two 1/2" FNPT cable entries	2
Panel Mount, Remote Transmitter w/ two 1/2" FNPT cable entries and w/Digital Display. <i>Specify cable length in Block 10</i>	4
Panel Mount, Integral Transmitter, w/ two M20x1.5 cable entries	A
Panel Mount, Integral Transmitter with Local Digital Display, w/ two M20x1.5 cable entries	B
Panel Mount, Remote Transmitter w/ two M20x1.5 cable entries and w/Digital Display. <i>Specify cable length in Block 10</i>	C

### Pipe Installation, Display/Transmitter Mounting Orientation and Flow Direction (Block 2)

Horizontal Pipe	Code	Vertical Pipe	Code
Top mnt, display face frwd, flow L-R	F	Side mnt L, display face frwd, flow up	M
Top mnt, display face frwd, flow R-L	G	Side mnt R, display face frwd, flow up	N
Side mnt, display face up, flow L-R	H	Side mnt L, display face frwd, flow down	P
Side mnt, display face up, flow R-L	J	Side mnt R, display face frwd, flow down	R
Side mnt, display face down, flow L-R	K	<i>For visual representation, refer to FCI drawing number 020943</i>	
Side mnt, display face down, flow R-L	L		

Power Supply (Block 3)	Code
DC; 18 - 36V	1
AC; 85 - 265 V, 50/60 Hz	2

Line Size (Block 4)	Code
1/4" <i>(Available only with NPT, Block 5 must be Code E or N)<sup>5</sup></i>	C
1/2"	E
3/4"	F
1"	G
1-1/2"	H
2"	J

Process Connection Type (Block 5)	Code
Female NPT	E
Male NPT	N
Flanged, #150 CLASS	F
Other; agency approved, customer specified <i>(If selected, Block 6 and 7 which follow must also be Code WW only)</i>	W

Process Connection Size, Material, Rating, Finish Details (Block 6 & 7)	Code
1/4" NPT (must be selected if Block 4 is Code C)	Q0
1/2" NPT	H0
3/4" NPT	T0
1" NPT	10
1-1/2" NPT	B0
2" NPT	20
1/2" ANSI flanged 150 lb RF ANSI 16.5, 316L Stainless steel	HG
3/4" ANSI flanged 150 lb RF ANSI 16.5, 316L Stainless steel	TG
1" ANSI flanged 150 lb RF ANSI 16.5, 316L Stainless steel	1G
1-1/2" ANSI flanged 150 lb RF ANSI 16.5, 316L Stainless steel	BG
2" ANSI flanged 150 lb RF ANSI 16.5, 316L Stainless steel	2G
DN15 DIN flanged PN40, Form C per DIN2526 or Form B1 per DIN EN1092-1 in 316L ss	D3
DN25 DIN flanged PN40, Form C per DIN2526 or Form B1 per DIN EN1092-1 in 316L ss	E3
DN40 DIN flanged PN40, Form C per DIN2526 or Form B1 per DIN EN1092-1 in 316L ss	G3
DN50 DIN flanged PN16, Form C per DIN2526 or Form B1 per DIN EN1092-1 in 316L ss	J2
Other; agency approved, customer specified	WW

Gas Medium and System Calibration <sup>2</sup> (Block 8)	Code
Air	B
Air Equivalence (Oxygen, Chlorine, Ammonia, etc.)	C
Nitrogen, Helium, Argon, CD <sub>2</sub> , Compressed Air	E
Hydrocarbons (e.g. Natural Gas, Ethane, Methane, Propane, Ethylene, Propylene, Mixed)	F
Hydrogen or hydrogen mixture	G
Air, Compressed Air	H
Air Equivalence (e.g. Oxygen, Chlorine, Ammonia, etc.)	J
Nitrogen, Argon	K
CO <sub>2</sub> , Ethylene, Ethane	L
Propane, Propylene	M
Butane, Pentane	N
Methane, Helium, Natural Gas	P
Hydrogen	R

Calibration <sup>3</sup> and Calibration Temperature Conditions (Block 9)	Code
High Accuracy 1% Calibration and Standard Conditions +40°F to 100°F [+4°C to 38°C] w/Vortab	Q
High Accuracy 1% Calibration and Extended Temperature Compensation 0°F to 250°F [-18°C to 121°C] w/Vortab	T
Other, Agency approved, customer specified	W

Interconnecting Cable Length for Remote Configurations <sup>4</sup> (Block 10)	Code
Not required <i>(Specify with integral configurations)</i>	0
10' [3 meters]	A
25' [7.6 meters]	B
50' [15 meters]	C
Custom length <i>(Cannot exceed 50' [15 meters])</i>	W

Optional Accessories	
Part Number	Description
019819-01	Software Interface Package for PDA/PalmOS
020802-01	PDA, Palm® model Tungsten™ E2
FC88	Portable Hand-held Communicator
014108-02	PC Interface Communications Kit, For RS232 serial port connection
DM10-N	Digital Display/Readout, LCD, 4-20mA loop pow
DM10-FC	DM10 with FM and CSA approvals
DM10-KIT1	Panel Mount Kit for DM10
DM10-KIT2	2 inch (52 mm) Pipe Mount Kit for DM10 <i>(Stainless steel)</i>
DM15	Digital Display/Readout, LED 115/230 Vac powered
DM15-ALM	Same as DM-15 with user programmable alarm limit, relay output
DM20	Digital Display Readout, 8-digit LCD Pulse totalizer/counter

### Notes

- Must use FCI's AVAL program to determine letter code. AVAL is a custom flow meter optimizer program which considers gas medium, flow range, pipe size and other conditions to determine best calibration and supplies FCI letter code to be used here. AVAL is available on-line at [www.fluidcomponents.com](http://www.fluidcomponents.com) or consult local FCI representative/distributor.
- Calibration accuracy is ±% of reading, ±0.5% of full scale.
- Fixed cable length with instrument calibrated together as a matched set. Cable may be coiled, but not cut.
- Certified Material Test Report (CMTR) not available with ST75V 1/4".

Visit FCI online at [www.FluidComponents.com](http://www.FluidComponents.com)  
FCI is ISO 9001:2000 and AS9100 Certified

**FCI FLUID COMPONENTS INTERNATIONAL LLC**  
Locally Represented By:

**FCI World Headquarters**  
1755 La Costa Meadows Drive | San Marcos, California 92078 USA | Phone: 760-744-6950 Toll Free (US): 800-854-1993 Fax: 760-736-6250

**FCI Europe**  
Persephonestraat 3-01 | 5047 TT Tilburg, The Netherlands | Phone: 31-13-5159989 Fax: 31-13-5799036

**FCI Measurement and Control Technology (Beijing) Co., LTD** | [www.fluidcomponents.cn](http://www.fluidcomponents.cn)  
Room 107, Xianfeng Building II, No.7 Kaituo Road, Shangdi IT Industry Base, Haidian District | Beijing 100085, P. R. China  
Phone: 86-10-82782381 Fax: 86-10-58851152

**NOTICE OF PROPRIETARY RIGHTS**

This document contains confidential and/or proprietary information which is the property of Fluid Components International, LLC (FCI). Disclosure of this data to you is expressly conditional upon your written agreement to use it solely for the use within your company only and does not include manufacture or processing use. Any other use is strictly prohibited without the prior written consent of FCI.

REV	DESCRIPTION	DATE	APPROVED

**HORIZONTAL MOUNTINGS**

<p><b>CODE F:</b></p> <p>TOP MNT, DISPLAY FORWARD FLOW LEFT TO RIGHT</p>	<p><b>CODE G:</b></p> <p>TOP MNT, DISPLAY FORWARD FLOW RIGHT TO LEFT</p>	<p><b>CODE H:</b></p> <p>SIDE MOUNT, DISPLAY UP FLOW LEFT TO RIGHT</p>	<p><b>CODE J:</b></p> <p>SIDE MOUNT, DISPLAY UP FLOW RIGHT TO LEFT</p>	<p><b>CODE K:</b></p> <p>SIDE MOUNT, DISPLAY DOWN FLOW LEFT TO RIGHT</p>	<p><b>CODE L:</b></p> <p>SIDE MOUNT, DISPLAY DOWN FLOW RIGHT TO LEFT</p>
--	--	--	--	--	--

**VERTICAL MOUNTINGS**

<p><b>CODE M:</b></p> <p>SIDE MOUNT LEFT DISPLAY FORWARD FLOW UP</p>	<p><b>CODE N:</b></p> <p>SIDE MOUNT RIGHT DISPLAY FORWARD FLOW UP</p>	<p><b>CODE P:</b></p> <p>SIDE MOUNT LEFT DISPLAY FORWARD FLOW DOWN</p>	<p><b>CODE R:</b></p> <p>SIDE MOUNT RIGHT DISPLAY FORWARD FLOW DOWN</p>
--	---	--	---

△ FLOW ARROW ON TOP AS SHOWN

- THE LCD DISPLAY CAN BE USER ROTATED AND VIEWED AT ANY 90 DEGREE ORIENTATION.
- IN REMOTE ELECTRONIC CONFIGURATIONS, THE LOCAL ENCLOSURE WILL BE ORIENTED AS SHOWN WITH SOLID COVER ON BOTH SIDES. INTERCONNECTING TERMINALS LOCATED INSIDE.
- THIS DRAWING IS GENERIC IN NATURE, FOR SPECIFIC MODEL TYPE, ORIENTATION, CUSTOMER PROCESS CONNECTION, ETC, REFER TO IO&M MANUAL.

NOTES: UNLESS OTHERWISE SPECIFIED

UNLESS OTHERWISE SPECIFIED DIMENSIONS ARE IN INCHES TOLERANCES DECIMALS ANGULAR		CONTRACT NO.	
NEXT ASSY	USED ON	APPROVED	APPROVED
APPLICATION		CONTRACT	DESIGN L. FLUSTING 7/16/07
THIRD ANGLE PROJECTION		QVAL	CHECK
		MFG	DATE
DO NOT SCALE DRAWING		DES.	REV
PARTS TO BE FREE OF BURRS & CHIPS EDGES		D 64818	Q20943
SCALE NONE		SHEET 1 OF 1	TITLE <b>ST75/ST75V, ASSEMBLY ORIENTATION</b>

**Anexo 4: Protocolos de Verificación de Medición de  
Caudalímetro Másico Térmico**

**VERIFICACION DE INSTRUMENTOS - PETROBRAS**

Nro. 1.2.1.11-2012-0000-RE-I-OM-1A

Hoja: 1 de: 5

REALIZADO AREA DE INSTRUMENTACIÓN Y CONTROL

AUDITADO COORDINACION MANTENIMIENTO

**FORMATO DE VERIFICACIÓN**

Fecha: Marzo - Mayo 2012 Rango de Verificación: 1020 - 102000 SCFD  
 Tag: FT-1105 % Error Máximo: 1% de Span  
 Ubicación: Separador de Pruebas 5 Salida de comunicación: 4-20 mA  
 Fabricante: FCI Alimentación eléctrica: 24 Vdc  
 Modelo: ST-75V Procedimiento: PE- 0076  
 Número de Serie: 1918528 Lugar de Verificación: Campo  
 Función del Instrumento: Medición de Gas en Salida de Separador 5 - Batería OR-11

**COMPROBACION CAUDALES**

N°	Fecha	Hora	VALORES ENCONTRADOS (SCFD)			
			Placa Orificio	Másico Térmico	Diferencia entre Medidores (% lectura)	Diferencia entre medidores(% span)
1	07/03/2012	15:00	9420	9715	3.128	0.292
2	07/03/2012	15:05	10030	10830	7.979	0.793
3	07/03/2012	15:10	11700	12061	3.082	0.357
4	07/03/2012	15:15	14530	14537	0.048	0.007
5	07/03/2012	15:20	14820	14820	0.000	0.000
6	07/03/2012	15:25	18560	18583	0.125	0.023
7	14/03/2012	15:00	18990	19029	0.203	0.038
8	14/03/2012	15:05	23170	23228	0.250	0.057
9	14/03/2012	15:10	23832	23918	0.363	0.086
10	14/03/2012	15:15	26090	26113	0.087	0.023
11	14/03/2012	15:20	26280	26327	0.179	0.046
12	21/03/2012	15:20	14080	14912	5.908	0.824
13	14/03/2012	15:25	14240	14249	0.064	0.009
14	21/03/2012	15:00	17460	20525	17.556	3.036

Máxima Desviación	17.556	3.036
Mínima Desviación	0.000	0.000
Promedio de Desviaciones	2.784	0.399

PERSONAL:  
Realizado por Juan Arias Suárez

EQUIPOS DE PRUEBA:

OBSERVACIONES:

**VERIFICACION DE INSTRUMENTOS - PETROBRAS**

Nro: 1.2.1.11-2012-0000-RE-I-OM-1A

Hoja: 2 de 5

REALIZADO AREA DE INSTRUMENTACIÓN Y CONTROL

AUDITADO COORDINACION MANTENIMIENTO

**FORMATO DE VERIFICACIÓN**

Fecha:	Marzo - Mayo 2012	Rango de Verificación:	1020 - 102000 SCFD
Tag:	FT-1105	% Error Máximo:	1% de Span
Ubicación:	Separador de Pruebas 5	Salida de comunicación:	4-20 mA
Fabricante:	FCI	Alimentación eléctrica:	24 Vdc
Modelo:	ST-75V	Procedimiento:	PE- 0076
Número de Serie:	1918528	Lugar de Verificación:	Campo
Función del Instrumento:	Medición de Gas en Salida de Separador 5 - Batería OR-11		

**COMPROBACION CAUDALES**

N°	Fecha	Hora	VALORES ENCONTRADOS (SCFD)			
			Placa Orificio	Másico Térmico	Diferencia entre Medidores (% lectura)	Diferencia entre medidores(% span)
1	21/03/2012	15:05	26100	26213	0.433	0.112
2	21/03/2012	15:10	26310	26403	0.354	0.092
3	21/03/2012	15:15	29080	29174	0.323	0.093
4	21/03/2012	15:25	9620	14133	46.910	4.469
5	04/04/2012	15:00	10640	11601	9.034	0.952
6	04/04/2012	15:05	11200	11269	0.618	0.069
7	04/04/2012	15:10	11800	11964	1.394	0.163
8	04/04/2012	15:15	12140	12140	0.002	0.000
9	04/04/2012	15:20	17070	17879	4.737	0.801
10	04/04/2012	15:25	11110	11132	0.199	0.022
11	11/04/2012	15:00	11130	11158	0.248	0.027
12	11/04/2012	15:05	11460	12154	6.059	0.688
13	11/04/2012	15:10	12640	13283	5.086	0.637
14	11/04/2012	15:15	25150	25274	0.491	0.122

Máxima Desviación	46.910	4.469
Mínima Desviación	0.002	0.000
Promedio de Desviaciones	5.421	0.589

PERSONAL:  
Realizado por Juan Arias Suárez

EQUIPOS DE PRUEBA:

OBSERVACIONES:

**VERIFICACION DE INSTRUMENTOS - PETROBRA S**

Nº. 1.2.1.11-2012-0000-RE-I-OM-1A

Hoja: 3 de 5

REALIZADO AREA DE INSTRUMENTACIÓN Y CONTROL

AUDITADO COORDINACION MANTENIMIENTO

**FORMATO DE VERIFICACIÓN**

Fecha:	Marzo - Mayo 2012	Rango de Verificación:	1020 - 102000 SCFD
Tag:	FT-1105	% Error Máximo:	1% de Span
Ubicación:	Separador de Pruebas 5	Salida de comunicación:	4-20 mA
Fabricante:	FCI	Alimentación eléctrica:	24 Vdc
Modelo:	ST-75V	Procedimiento:	PE- 0076
Número de Serie:	1918528	Lugar de Verificación:	Campo
Función del Instrumento:	Medición de Gas en Salida de Separador 5 - Batería OR-11		

**COMPROBACION CAUDALES**

N°	Fecha	Hora	VALORES ENCONTRADOS (SCFD)			
			Placa Orificio	Másico Térmico	Diferencia entre Medidores (% lectura)	Diferencia entre medidores(% span)
1	11/04/2012	15:20	26910	26923	0.046	0.012
2	18/04/2012	15:25	9440	9868	4.534	0.424
3	11/04/2012	15:25	12290	13634	10.936	1.331
4	18/04/2012	15:00	12430	12703	2.200	0.271
5	18/04/2012	15:05	12830	13634	6.269	0.796
6	18/04/2012	15:10	13450	13473	0.170	0.023
7	18/04/2012	15:15	14630	19692	34.597	5.012
8	18/04/2012	15:20	19060	19408	1.828	0.345
9	25/04/2012	15:00	9840	11456	16.420	1.600
10	25/04/2012	15:05	10837	11135	2.756	0.296
11	25/04/2012	15:10	14460	16571	14.599	2.091
12	25/04/2012	15:25	15290	16050	4.969	0.752
13	25/04/2012	15:15	15600	16803	6.428	0.993
14	25/04/2012	15:20	20440	20615	0.856	0.173

Máxima Desviación	34.597	5.012
Mínima Desviación	0.046	0.012
Promedio de Desviaciones	7.615	1.009

PERSONAL:  
Realizado por Juan Arias Suárez

EQUIPOS DE PRUEBA:

OBSERVACIONES:

**VERIFICACION DE INSTRUMENTOS - PETROBRAS**

Nro. 1.2.1.11-2012-0000-RE-I-OM-

Hoja: 4 de 5

REALIZADO: AREA DE INSTRUMENTACIÓN Y CONTROL

AUDITADO: COORDINACION MANTENIMIENTO

**FORMATO DE VERIFICACIÓN**

Fecha:	Marzo - Mayo 2012	Rango de Verificación:	1020 - 102000 SCFD
Tag:	FT-1105	% Error Máximo:	1% de Span
Ubicación:	Separador de Pruebas 5	Salida de comunicación:	4-20 mA
Fabricante:	FCI	Alimentación eléctrica:	24 Vdc
Modelo:	ST-75V	Procedimiento:	PE- 0076
Número de Serie:	1918528	Lugar de Verificación:	Campo
Función del Instrumento:	Medición de Gas en Salida de Separador 5 - Batería OR-11		

**COMPROBACION CAUDALES**

N°	Fecha	Hora	VALORES ENCONTRADOS (SCFD)			
			Placa Orificio	Másico Térmico	Diferencia entre Medidores (% lectura)	Diferencia entre medidores(% span)
1	02/05/2012	15:00	200	2600	1200.000	2.377
2	02/05/2012	15:05	7813	8620	10.333	0.799
3	02/05/2012	15:10	5120	2356	53.979	2.737
4	02/05/2012	15:15	5540	9067	63.670	3.493
5	02/05/2012	15:20	6170	1884	69.473	4.245
6	02/05/2012	15:25	4650	14877	219.944	10.128
7	09/05/2012	15:00	1130	17775	1473.009	16.483
8	09/05/2012	15:10	330	21020	6269.727	20.489
9	09/05/2012	15:20	7310	9436	29.082	2.105
10	09/05/2012	15:25	1102	19132	1636.152	17.855
11	16/05/2012	15:00	6990	15418	120.565	8.346
12	16/05/2012	15:05	6430	7822	21.653	1.379
13	16/05/2012	15:10	2300	2578	12.074	0.275
14	16/05/2012	15:15	7720	12487	61.744	4.720

Máxima Desviación	6269.727	20.489
Mínima Desviación	10.333	0.275
Promedio de Desviaciones	802.958	6.817

PERSONAL:  
Realizado por Juan Arias Suárez

EQUIPOS DE PRUEBA:

OBSERVACIONES:



**VERIFICACION DE INSTRUMENTOS - P ETROBRAS**

Nro. 1.2.1.11-2012-0000-RE-I-OM-1A

Hoja: 5 de: 5

REALIZADO AREA DE INSTRUMENTACIÓN Y CONTROL

AUDITADO COORDINACION MANTENIMIENTO

**FORMATO DE VERIFICACIÓN**

Fecha: Marzo - Mayo 2012 Rango de Verificación: 1020 - 102000 SCFD  
 Tag: FT-1105 % Error Máximo: 1% de Span  
 Ubicación: Separador de Pruebas 5 Salida de comunicación: 4-20 mA  
 Fabricante: FCI Alimentación eléctrica: 24 Vdc  
 Modelo: ST-75V Procedimiento: PE- 0076  
 Número de Serie: 1918528 Lugar de Verificación: Campo  
 Función del Instrumento: Medición de Gas en Salida de Separador 5 - Batería OR-11

**COMPROBACION CAUDALES**

N°	Fecha	Hora	VALORES ENCONTRADOS (SCFD)			
			Placa Orificio	Másico Térmico	Diferencia entre Medidores (% lectura)	Diferencia entre medidores(% span)
1	16/05/2012	15:20	4630	15942	244.309	11.202
2	16/05/2012	15:25	8340	9681	16.079	1.328
3	23/05/2012	15:00	5340	2594	51.433	2.720
4	23/05/2012	15:05	3270	7307	123.468	3.998
5	23/05/2012	15:10	7080	12357	74.534	5.226
6	23/05/2012	15:15	7710	9376	21.608	1.650
7	23/05/2012	15:20	8190	16134	97.001	7.867
8	23/05/2012	15:25	5500	6252	13.665	0.744
9	23/05/2012	15:30	3680	3876	5.329	0.194
10						
11						
12						
13						
14						

Máxima Desviación	244.309	11.202
Mínima Desviación	5.329	0.194
Promedio de Desviaciones	71.936	3.881

PERSONAL:

Realizado por Juan Arias Suárez

EQUIPOS DE PRUEBA:

OBSERVACIONES:

## **PLANOS**

**Plano 1: Plano de Montaje Caudalímetro Másico Térmico SP-  
1105 OR-11**



**Plano 2: Diagrama Unifilar Alimentación Caudalímetro**

**Másico Térmico SP-1105 OR-11**

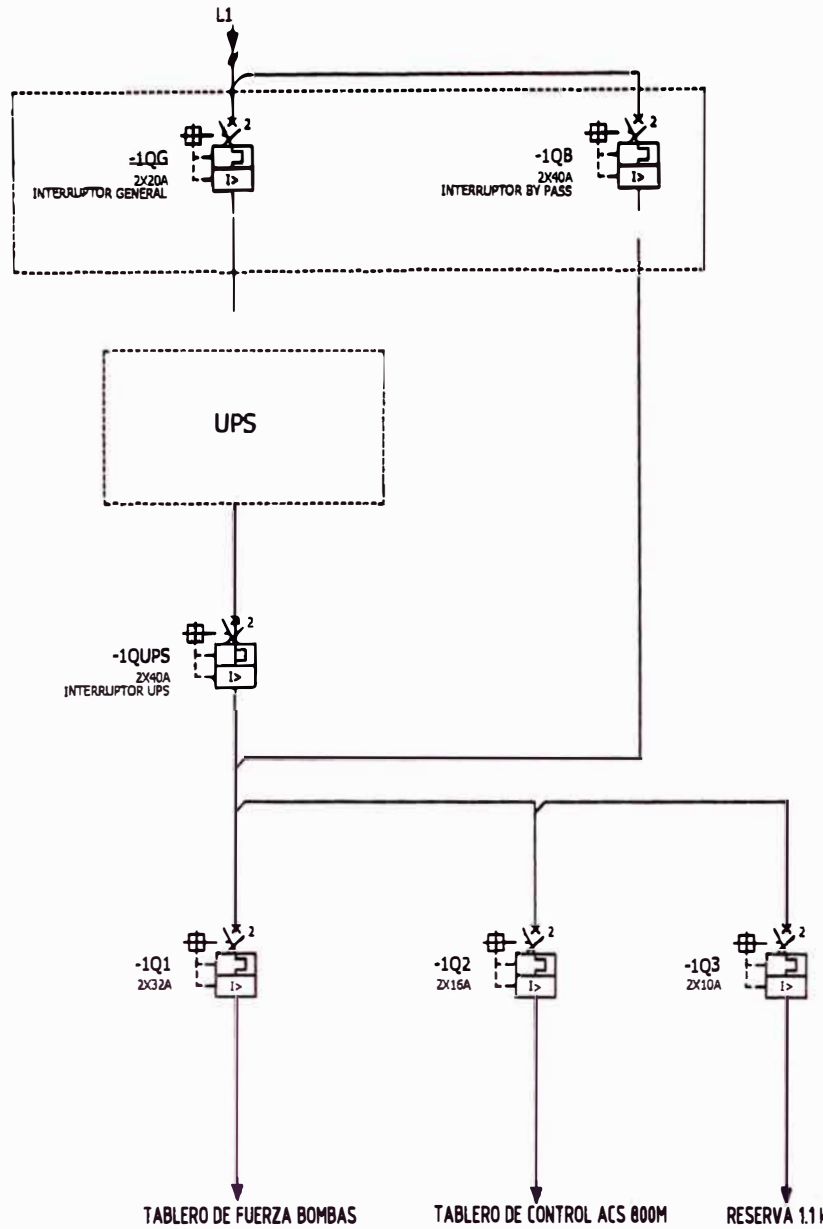

No.	REVISIONES	POR	FECHA	No.	N° PLANO DE REFERENCIA	TITULO DE PLANO DE REFERENCIA
A	EMISION ORIGINAL	MCO	09-2011			

				PROYECTO PILOTO DE MEDICION DE GAS DIAGRAMA UNIFILAR ALIMENTACION CAUDALIMETRO MASCICO TERMICO SP-1106 OR-11 (1 de 2)	
CALIDAD: E. BARBUTO	REVISADO: E. ALARCON	APROBADO: S. SANDOVAL	DISEÑADO: (blank)	REVISADO: (blank)	FECHA: DICIEMBRE 2011
PROYECTO: PBT-000-001	DISEÑADO: (blank)	APROBADO: (blank)	PROYECTANTE: (blank)	PROYECTO No. (blank)	ESCALA: (blank)
			PLANO No. IMPRESION: A.1.36-000-E-PL-1	REV: (blank)	

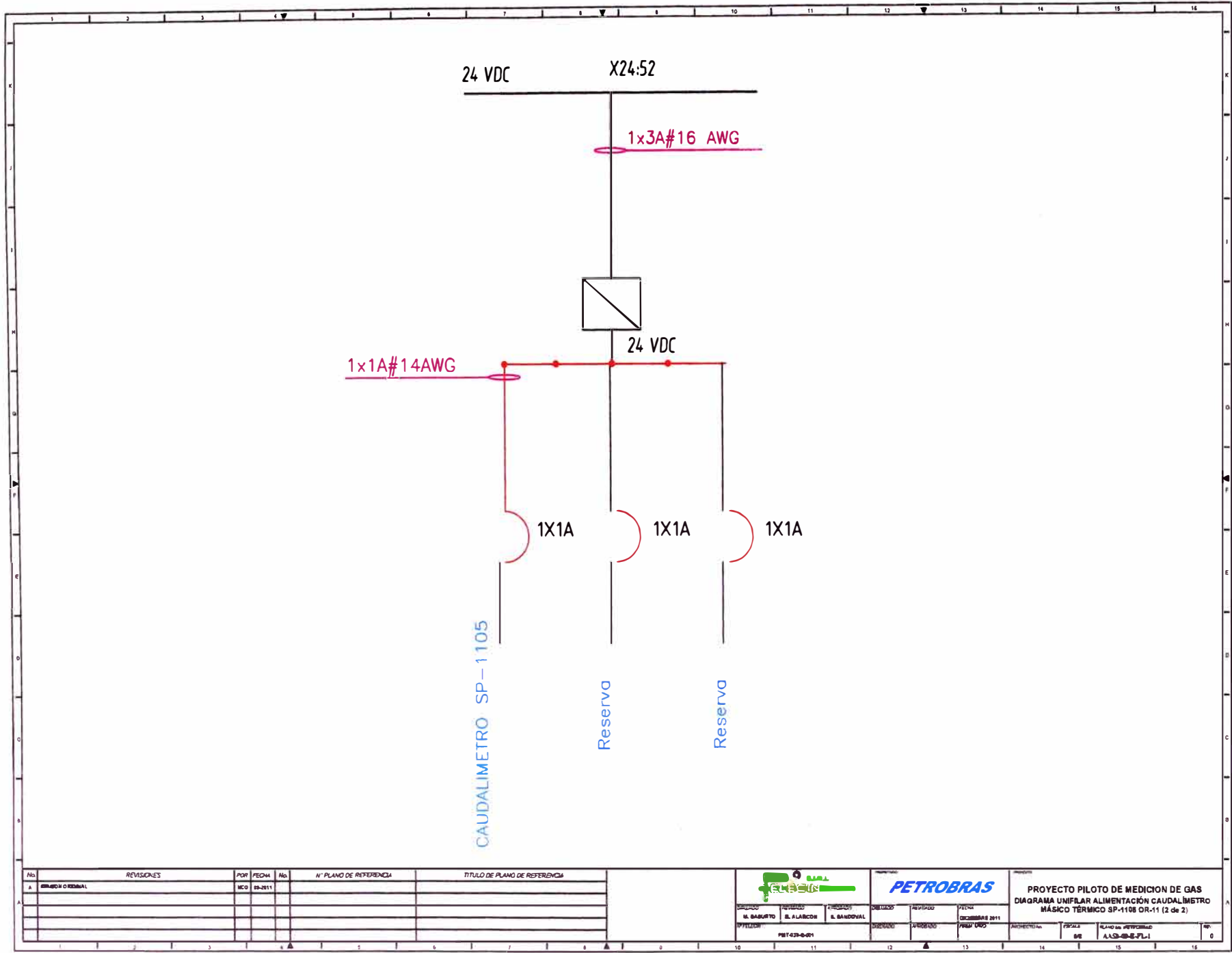

No.	REVISIONES	POR	FECHA	No.	N° PLANO DE REFERENCIA	TITULO DE PLANO DE REFERENCIA
A	DESIGNO ORIGINAL	MCO	02-2011			

**PETROBRAS**

GRUPO PETROBRAS

DEPARTAMENTO DE INGENIERIA DE SISTEMAS

PROYECTO: M. BABUETO, E. ALARCON, E. SANDOVAL

FECHA: DICIEMBRE 2011

PROYECTO No. 008

PLANO No. AAS-08-PL-1

NO. 0

PROYECTO PILOTO DE MEDICION DE GAS  
 DIAGRAMA UNIFILAR ALIMENTACION CAUDALIMETRO  
 MASCICO TERMICO SP-1108 OR-11 (2 de 2)